



Sanabil

Dr. Ribahan, M.Pd

READING COMPPREHENSION INSTRUCTIONAL DESIGN

(A Dick And Carey Model)

**READING COMPPREHENSION
INSTRUCTIONAL DESIGN
(DICK AND CAREY MODEL)**



This page is intentionally left blank

Dr. Ribahan, M.Pd

**READING COMPPREHENSION
INSTRUCTIONAL DESIGN
(DICK AND CAREY MODEL)**



Reading Comprehension Instructional Design (A Dick and Carey Model)

© Sanabil 2021

Penulis: Dr. Ribahan, M. Pd

Editor: Soni Ariawan, S.Pd., M.Ed

Layout: Kurniawan Arizona, M.Pd.

Desain Cover: Sanabil Creative

All rights reserved

Hak Cipta dilindungi Undang Undang

Dilarang memperbanyak dan menyebarkan sebagian atau keseluruhan isi buku dengan media cetak, digital atau elektronik untuk tujuan komersil tanpa izin tertulis dari penulis dan penerbit.

ISBN:

Cetakan 1: Oktober 2021

Penerbit:

Sanabil

Jl. Kerajinan 1 Blok C/13 Mataram

Telp. 0370- 7505946, Mobile: 081-805311362

Email: sanabilpublishing@gmail.com

www.sanabil.web.id

DAFTAR ISI

Halaman

Cover.....	i
Table of Contents.....	v
List of Tables.....	viii
List of Figures.....	ix
List of Abbreviation.....	xi
Foreword.....	xiii
Preface.....	xvii

CHAPTER I INTRODUCTION

A. Backround of the Study	1
B. Statement of the Problem	12
C. Objective of the Study	13
D. Methods.....	15

CHAPTER II THE NATURE OF READING

A. Definition of Reading.....	24
B. Purpose of Reading.....	26
C. Benefits of Reading.....	29
D. Models of Reading Process	31
E. Types of Reading	32
F. Principles Behind The Teaching of Reading.....	33
G. Theories Underlying Reading Instruction.....	38
H. Teaching Reading as a Foreign Language	41
I. Learning Reading Process.....	45
J. Reading Assessment.....	49

CHAPTER III THE NATURE OF READING COMPREHENSION

A. Definition of Reading Comprehension	56
B. Types of Reading Comprehension	59
C. Indicators of Reading Comprehension.....	60

D. Levels of Reading Comprehension.....	61
E. Strategies for Reading Comprehension	63
F. Skills of Reading Comprehension.....	70
G. Teaching Comprehension Strategies	72
H. Assessment of Reading Comprehension.....	75

CHAPTER IV TEACHING ENGLISH IN INDONESIAN ISLAMIC HIGHER EDUCATION

A. Short Overview	81
B. Objective of Reading Instruction.....	81
C. Material for Reading Instruction	83
D. Teaching and Learning Reading Approaches.....	84
E. Teaching Reading at UIN Mataram	86
F. Assessment of Reading	87

CHAPTER V INSTRUCTIONAL DEVELOPMENT

A. Concept of Instructional Development.....	94
B. Models of Instructional Development.....	96
C. The Dick and Carey Model of Instructional Design	107

CHAPTER VI MATERIAL DEVELOPMENT

A. Definition of Material Development.....	115
B. The Importance of Material Development.....	118
C. Principles of Material Development.....	120
D. Types of Teaching Materials	125
E. Material Selection	126
F. Criteria for A text Selection.....	128

CHAPTER VII ENGLISH FOR SPESIFIC PURPOSES (ESP)

A. An Overview of English for Spesific Purposes (ESP)	135
B. Definition of English for Spesific Purposes (ESP).....	137
C. Objectives in Teaching ESP.....	140
D. Needs Analysis in ESP	141
E. The Needs of Students in ESP Reading Class	147

F. Developing a Model of ESP Reading Class.....	148
---	-----

CHAPTER VIII PREVIOUS RELATED STUDIES

A. Review of Previous Related Studies	151
B. Conceptual Framework.....	153

CHAPTER IX PREVIOUS RELATED STUDIES

A. Research Findings.....	155
B. Discussion.....	187

CHAPTER X PREVIOUS RELATED STUDIES

A. Conclusion	190
B. Suggestion	191
C. Implication.....	192

REFERENCES	193
------------------	-----

SYNOPSIS	199
----------------	-----

GLOSSARIUM	200
------------------	-----

CURRICULUM VITAE.....	203
-----------------------	-----

LIST OF TABLES

	Page
Tabel 1 The Result of Needs Analysis	158
Tabel 2 The Result of Pre-Test	177
Tabel 3 The Distribution of Pre-Test Scores	178
Tabel 4 The Distribution of Post Test-Scores	180

LIST OF FIGURES

	Page
Figure 1 The Dick and Carey Systems Approach Model for Designing Instruction	112
Figure 2 The Adaptation of the Dick and Carey Model for Developing Materials.....	115
Figure 3 The Hutchinson and Waters model for designing ESP reading materials.....	149
Figure 4 The Procedure of Developing the Draft of the Materials	167



This page is intentionally left blank

LIST OF ABBREVIATION

ESP	English for Spesific Purposes
UIN	<i>Universitas Islam Negeri</i>
MKU	Mata Kuliah Umum
CLT	Communicative Language Teaching
R&D	Research & Development

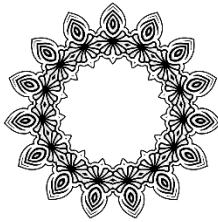

This page is intentionally left blank

DEAN PREFACE

Alhamdulillah, all praises belong only to Allah SWT. Hopefully *salawat* and *salam* will always be delivered to the great Prophet Muhammad SAW, along with His family, friends and followers until the day of the resurrection. Thanks to the grace and guidance of Allah SWT, the textbook and reference writing program has been completed.

The obligation of lecturers to write and produce books, both textbooks and reference books, has actually been regulated in Law Number 12 of 2012 concerning tertiary institutions and Law Number 14 of 2005 concerning Teachers and Lecturers and some other regulations. Article 12 of Law No.12 of 2012 clearly states that lecturers individually or in groups are required to write textbooks or textbooks published by tertiary institutions as a learning resource.

The textbook and reference book writing competition (KOBAR) 2020 held by Faculty of Tarbiyah and Teacher Training (FTK) is an effort to contribute to the implementation of the law above, which quantitatively, the research charts and publications of PTKI lecturers still have to be improved. Another goal is to improve the quality of learning by creating a conducive academic atmosphere and an effective, efficient learning process with easy access to learning resources for lecturers and students. This publication is also expected to support the advancement of lecturers' careers in the context of advancement of lecturer functional positions, which in turn will have an impact on the increase of the university and study program accreditation status.

Gradually, the Faculty continues to strive to increase the quantity and quality of the published book. There were 10 books in 2019 and increased quite significantly in 2021 into 75 reference books. The efforts of the faculty do not stop at the

publication level, but continue with the registration of Intellectual Property Rights (HKI) of the books at the Directorate General of Intellectual Property (DJKI) of the Ministry of Law and Human Rights of the Republic of Indonesia, would result 75 HKI for lecturers in 2021.

The 2021 textbook and reference competition is oriented towards the interconnection-integration between religion and science, with the spirit of UIN Mataram *Horizon Ilmu* with inter-multi-transdisciplinary science that discusses methods in conventional Islamic studies with deductive-normative-theological characteristics with contemporary humanities studies methods such as sociology, anthropology, psychology, economics, hermeneutics, phenomenology and also the natural sciences which have an inductive-rational character. Among the 100 books, there were 10 thematic titles that answer the epistemological problems of Islamic education, especially those related to the mission of the Indonesian Ministry of Religion such as Islamic moderation (*Islam wasathiyah*), inclusive education, anti-corruption education, character education, multicultural education, ethno-pedagogic, and online learning, education & gender issues, various Islamic boarding schools (coastal, entrepreneurial), and the most current themes, namely independent learning and independent campuses (Kampus Merdeka).

Representing the Faculty, I am grateful for the policies and support of the Rector of UIN Mataram Prof. Dr. H Mutawali, M.Ag and his staff, to 75 writers who contributed in the 2021 book competition, and the unforgettable editors from lecturers in the same field as well as publishers without a touch of *zauq*, the books will not be as attractive as these. There is no ivory that is not cracked; indeed there is still a shortage, both in substance and in technical writing. Through this "space", we expect critical suggestions from the readers. Hopefully this

agenda will become an *amal Jariyah* and bring blessings to the academic community of UIN Mataram and the ummah in general.



Mataram, 25 Oktober
2021
Dean

Dr. Jumarim, M.H.I
NIP. 197612312005011006



This page is intentionally left blank

PREFACE

First of all, I would like to thank Allah S.W.T, the Almighty God for giving me strength and patience that I am able to accomplish and complete this book. This book is entitled “*Reading Comprehension Instructional Design (Dick and Carey Model)*.”

Lack of references in the field regarding the practice of teaching reading comprehension encourage the writing of this book especially in the level of higher education. This book was written to provide readers with both scientific references and research results comprehensively from concepts, theories, design, stages of development to the form of implementation in the classroom. So far, this book presents a comprehensive scientific repository of reading comprehension teaching and learning for teachers, academicians and public who have a deep interest and curiosity about these approaches. Finally, the presence of this book is expected to bring advantages it becomes a model, especially for teachers, lecturers and researchers who want to design a systematic and scientific English reading comprehension instructional tools.

This book actually consists of ten chapters and the contents are presented in three major sections. The first section contains an introductory section which elaborate the background, problem formulations, and literature reviews that are relevant to the reading comprehension concepts. In the second section, the results of the study and discussion of the research are presented. In the third section, there is the concluding section containing conclusions, suggestions, and implications for readers.

Finally, the writer realize that this book is far from being complete so that the writer expects constructive input, criticism, and suggestion from readers so that the writing of this book will be better in the next editions.

Mataram 1 September 2021

The writer



This page is intentionally left blank

CHAPTER I INTRODUCTION

A. Background of the Study

Since English is an international language, many people want to learn and master it. They can learn English both in formal and informal situation. In formal situation, students learn English at school or university under the guidance of a teacher or attending a course program. Whereas in informal situation, students can learn English outside the classroom through interaction with other people or exposure to authentic language input. Rogers in Taher & Tam suggests that formal language learning is structured, purposeful, and school based. On the contrary, informal language learning is unstructured, unpurposeful but is the most extensive and most important part of all the learning that all of us do every day of our lives¹. Furthermore, Lightbown and Spada states that in the formal language learning setting, the focus of learning is on the language itself. On the contrary, in informal language learning setting the focus is on meaning². Needless to say, whether English language learning is to occur in formal or informal settings, students need to be exposed and accessed to a variety of language input.

English has been widely used as the language of science and technology. According to Drubin and Kellogg, English is now used almost exclusively as the language of science. Though up till now, the world Scientist Association has not officially declared the language as the official language of science, but almost all activities in science and technology are carried in the language.³ Many great books, manuals,

¹ Taher Bahrani and Tam Shu Sim, "Informal Language Learning Setting: Technology or Social Interaction?," *Turkish Online Journal of Educational Technology-TOJET* 11, no. 2 (2012): 142–149.

² Patsy M Lightbown and Nina Spada, *How Languages Are Learned. Oxford Handbooks for Language Teachers*, (Oxford: Oxford university press, 2013).

³ David G Drubin and Douglas R Kellogg, "English as the Universal Language of Science: Opportunities and Challenges," *Molecular biology of the cell* 23, no. 8 (2012): 1399.

technical procedures, journals, and others are presented in English. Regarding journals, English is considered the best way to share and disseminate one's research findings with other scientists in other parts of the world, although many countries today still publish journals in their native language. Teachers and students will be demanded to have English skills if they expect to understand the idea or the message of what they are reading. English has increasingly become more important for learning of many subjects especially at the university level which relies to a great extent on textbooks written in English. The need to master English seems to become a necessity for students to widen their insight and fulfill their communicative needs. So far, the mastery of English will open a great opportunity for people of Indonesia in order to be able to adopt and adapt with the latest development of science and technology in the world, and to provide an easyness for Indonesian people to interact and socialize with global community.

The main reason for university students to learn English is to help them acquire information in their field of study through textbooks, articles, lecture notes, technical instructions and others. In this context, one of the skills the students need to master is reading. Reading in English needs to be learnt by the students because many sources of information as mentioned earlier, both academic and non academic matters are written in English. In line with this, Harmer argues that many students want to be able to read texts in English either for their careers, for study purposes or simply for pleasures.⁴ Based on these purposes, teaching reading should be directed to develop students' reading skill so that they can read English texts effectively and efficiently. To be able to read effectively and efficiently, students should have sufficient knowledge about reading. They also should have a good command of English vocabulary, grammar, contexts. By reading, students will get a lot of information

⁴ Jeremy Harmer, *How to Teach English: An Introduction to the Practice of English Language Teaching*. (England: Addison Wesley Longman Limited, 2011).

and ideas. Also, they will be exposed to variety of inputs and they can improve their own language and experiences.

The teaching of English is a continuous process. As far as this educational activity involves a great deal of students in it and it is determined by many factors for its success, there must be a systematic plan or program to improve its implementation. The task of the teacher is vital in planning courses, preparing teaching materials and teaching their class, while students can get benefits from the organized program in attempt to master English. One concrete thing the teacher can do for example is to choose and apply appropriate strategies to help the students understand the text they are learning more easily. Another thing the teacher can do is to prepare suitable and interesting lesson (texts) for the students to stimulate activeness and participate in teaching and learning process.

Today, English is a global language. More than a billion people worldwide speak, learn, teach and use English as a first, second, foreign and international language in more than a hundred countries such as Russia, Germany, China, Indonesia, Thailand and other countries.⁵ English has also been preferred and chosen as for education, occupation, and communication. The mastery of English is a strategic way to enter into global era i.e. the era of openness in which the quality and the skill of using English, written or spoken, are required in order to be able to professionally compete with other developed countries, especially in the process of transferring knowledge and technology. For those who have mastered English, becoming involved in the global era in which the association with foreign countries cannot be avoided, is not problem anymore. With the English ability they have, of course, they can access information easily, they can make certain relationships easily and the most important is they can communicate easily with those who use English as a means of communication.

⁵ David Crystal, *English as a Global Language (2nd Ed.)* (Cambridge: Cambridge university press, 2003).

At university level, foreign languages especially Arabic and English are very important for the students to prepare them communicating in those languages. In <http://britishcourse.com/the-importance-of-english-for-college-students.php>, it is stated that the mastery of English is very important for university students; however, there are still many of them who have not realized the need for mastery of English. Currently, English proficiency is required for those who plans to continue his study to master and doctoral program, in home country or abroad. Here the students should be able to use English well, written or spoken. Besides, the mastery of English language is also needed as one of the compulsory requirements to obtain a postgraduate scholarship (master and doctoral). Furthermore, English becomes one of the requirements for applying a job. Almost all professional jobs require a good competence of English. Moreover, an international company that the salary is very high also need English competence. Even, those who master and understand English, he or she would get good position in their job.⁶

Meanwhile, Adil stated that the English language plays a very important role for the students in education. In today's modern world the English language becomes the basic language of education. The English language is the language most studied all over the world. All over the world, the English language is the main language of the study of every education system. For the students, it's very important to learn and understand the English language for further study. In most of the school, colleges, and universities the education is in the English language. For understanding the books, lectures, assignments it's necessary to learn the English language first. Most of the students want to go to foreign countries to study. Survival without understanding and speaking the English language in foreign countries is very difficult. So, learning the English language is very important for those students who want to study in foreign countries. Most of

⁶ "The Importance of English for College Students," <http://britishcourse.com/the-importance-of-english-for-college-students.php>.

the science subjects and upcoming technology and inventions are in the English language.⁷

UIN Mataram is one of the leading universities in West Nusa Tenggara, where English is also taught to provide students with larger opportunities to learn English, so that they can develop their English skills. So far, by mastering English, it is expected that the students of UIN Mataram can communicate well with international community, they can continue their study to the higher level, and of course they are expected to get a good job for their future. English has become important and compulsory subject at UIN Mataram to support the students in achieving their academic goals.

In the curriculum of UIN Mataram, English is one of the foreign languages, besides Arabic, offered to students in order that they can communicate in English. The total credit for English subject at UIN Mataram is more than two. This is intended to give larger opportunities to students to learn English. However, the teaching of English at UIN Mataram has a number of problems that need to be taken into account. The main problem is that an appropriate English subject material for students was not available. In another word, there is no suitable materials for the teaching of English at UIN Mataram that can help students learn English better. The material used at present does not match the needs and characteristics of the students. Other problems which currently arise are:

- 1) the motivation and interest of the students in learning English are still low. This condition is indicated by small participation of the students in teaching and learning process and less presence of the students during the course.
- 2) the achievement of the students in English especially in reading course is not satisfactory. The bad result of formative and summative evaluation during the course support this fact.

⁷ Muhammad Adil, "Importance of English Language for the Students in Education," <https://adilblogger.com/importance-english-language-students-education/>.

- 3) the learning activity is not supported with enough facility. Instructional tools such LCD, teaching media, laboratory are not enough in quantity, even some are unavailable.
- 4) the students are not aware of the benefits of learning English. there are great number of students do not care and realize about the importance and advantages of English for their career and professional development.

Regarding the aforementioned problems, something has to be done in order to change the unfavorable situation into a better one. It is considered important to develop materials as a source of learning for students and an alternative to cope with the problems of teaching and learning English at UIN Mataram, by considering the needs and characteristics of the students. Materials play a very important role that they determine the success of any teaching and learning process. A question may come to the surface dealing with this fact is that how can the teaching and learning activities can be carried out well without the availability of materials. Thus, teaching materials are great of importance to support teaching and learning process.

The primary goal of teaching English at UIN Mataram is to develop the English skills or ability of the students in order that they can understand and comprehend any English references such as textbooks, journals, newspaper, magazines and other sources.⁸ As one of the general subjects, English has been treated as a compulsory subject taught to the students that will determine whether they may continue their study or will have to quit from UIN Mataram. Stated in another word, when the students fail in examination, they have to recourse in the next semester when the subject is offered, untill the pass the examination or test.

Considering the important status of English in the curriculum of UIN Mataram, the materials of reading comprehension for the students are chosen as the ones to be developed in this study.

⁸ Kurikulum UIN Mataram, 1994.

Through reading the students are exposed to a wide variety of texts or passages, to learn the aspects of language such as vocabulary, grammar, punctuation, and the way sentences and paragraph are constructed. Beside that, they are expected to be able to do a number of things with a reading text, like to scan the text for particular bits of information they are searching for or to skim a text to get a general idea, to find the purpose of the author, to draw inferences and so on.

In relation to the teaching of reading, coursebook in English for university students are essential to help them learn English well, particularly the reading skill. Without denial, a courbook has many advantages to support the tecahing and learning activities. Hutchinson and Torres argue that during periods of change, a course book can serve as a tool for supporting teachers and as an instrument of modifications and alterations. Most teachers consider course books to be valuable aids that offer useful material and support. Also learners need course books to guide them towards the hard process of learning. A course book reinforces the teachers work and offers material for further learning and revision. In brief, a course book provides teachers and learners with a structure of teaching and learning, methodological support and opportunities for revision and preparation. Moreover, it gives teachers a relief as it reduces the heavy load of preparation, saves time and makes teaching and learning easier.⁹ In addition, Spyropoulou confirms that the coursebook conveniently and compactly serves a number of useful purposes: it bestows a notional authority on the teacher as mediator of its content; it provides students with a quantifiable record and token of what is to be studied or 'learned'; it acts as a resource and point of reference; often, it is the tangible element that gives a language course face validity to many learners and teachers. Where no curriculum exists it may form an entire study course. The prominent role that course books play should therefore make them

⁹ E Hutchinson, T. and Torres, "The Textbook as Agent of Change," *ELT Journal* 48, no. 4 (1994): 15–28.

the focus of attention with regard to theoretical and practical ideas on the nature of effective pedagogy, important in assessing and understanding their limitations, parameters, and potential.¹⁰ Furthermore, O'Neill states that there are four reasons why it is necessary to use course book. *Firstly*, most parts from coursebook can be used in teaching and learning process because it is designed for classroom usage. *Secondly*, it makes students able to review the previous materials or what they want to learn again and to study the next material before they enter the classroom. *Thirdly*, course book provide students materials for their study, and *fourthly*, course book can give what teachers need to reach learning purposes, give what student'd need, and be main source for the students during their study.¹¹

Dick and Carey state that the instructional process involves instructor, learners and coursebook. Instructor is person who convey instruction, learners are a group of people who receive instruction, and textbooks are means of instruction through which instruction is conveyed. The content to be learned is contained in the text, and it is the instructor's responsibility to "teach" that content to the learners.¹² Thus, material in this case a coursebook is one of the important components of any classroom or language instruction besides teachers and students. It is a primary resource for use in the teaching-learning process.

Based on the preliminary study conducted at UIN Mataram, it was found that the materials for reading comprehension course at UIN Mataram are compiled by Unit for language Development (UPT Pusat Bahasa UIN Mataram). The materials on the textbook are

¹⁰ Anastasia Spyropoulou, "The Significance of the ELT Coursebook," <https://www.linkedin.com/pulse/significance-elt-coursebook-anastasia-spyropoulou>.

¹¹ Robert O'Neill, "Why Use Textbooks?," *ELT journal* 36, no. 2 (1982): 104–111.

¹² Walter Dick, Lou Carey, and J O Carey, *The Systematic Design of Instruction. 6th, New York: Longmann, 2001.*

usually in the form of texts or passages taken from any sources which frequently do not match with the needs and characteristics of the students namely their own content subject. In general, the materials are not organized and structured well or they do not follow the standard rules or principles which underly the development of instructional materials. The instruction process using the existing material have some weaknesses, some of which are the following:

- 1) the instruction is not proceeded by an effort to attract the students' interest; therefore, it does not quite stimulate the students to learn. In relation to this, the physical appearances and lay out of the materials are not interesting and they are designed as what they are without any creativity and less aesthetic.
- 2) the instruction does not begin with information about the instructional objective. A good instructional materials or course book should be completed with clear objectives about what the students are going to achieve after joining the course and the students have the right to know them.
- 3) the instruction tends to be so monotonous that the students lose their interest and motivation to learn. As the materials lack of activities and tasks, the teacher cannot improvise and do various things on the materials. Also, the teacher does not become flexible and independent in applying the method or the strategy she or he considered effective.
- 4) the instruction cannot obtain a maximum result due to the limitations of the available material. The results of mid and final test give clear indication for this problem. Achievement of the students in the two tests are not satisfactory enough. There are still many students who got below average grade or do not pass the test.

Specifically, for the teachers of English at UIN Mataram, how to develop the materials that agree with the needs of the students i.e. to connect the materials to the subject the students are majoring is the main problem. Often the materials are compiled in the way just

for the sake of availability; therefore, they tend to be ineffective, not functional and not applicable. Beside that, the teachers seem do not have enough space to create themselves the teaching materials he or she considered appropriate for their students because the materials have been prepared by institution and they will apply them for all classess or students.

For those reasons, the students of UIN Mataram need appropriate materials for reading comprehension course that meet their needs. Many books and researches confirmed that particularly in non-English department the main problem encountered is the lack of suitable instructional materials relevant to the specific English needs. One way to solve the problem is to develop a learning package which fulfills the students' requirement in terms of quality and attractiveness in the form of teaching materials, lecturer handbook and student handbook.

The materials which exist at present are in the form of a textbook, containing a collection of reading passages, and divided into several units. In another word, the existing materials are only in the form of compilation taken from a number of sources. The reading passages are not properly arranged – some of the reading passages are short, while some others are long. The reading passages are also not-well organized; they do not contain instructional objectives, they consist of a wide variety of topics, and they present the tasks or activities unsystematically. Besides, the selection of the texts does not consider the background and the level of the students; therefore, it is sometimes either difficult or easy for the students to study and understand the texts.

The materials do not appear to be effective since the texts are too general or free in terms of topics and contents. Almost all the topics and contents of the texts that are presented do not have connection with the major content subject of the students. As a consequence, the students lack interest and motivation to study English. In addition, the presentation of the materials does not quite

help the students improve their ability in learning English. The students should actually be able to learn many things from the material to enrich their English knowledge.

The materials also lack exercises and activities. They only cover a number of texts or passages to be read by the students and each text is followed by exercises in the form of questions to be answered. The exercises are so monotonous that they bore students. Besides, the materials lack coverage since the tasks or activities designed cannot enrich the materials and engage the student's participation.

As a result, the existing material cannot be implemented optimally in the teaching and learning process and it cannot achieve the expected goals. In short, the available material is not relevant to the curriculum, it does consider the needs of students, and it is not based on the principles of a good instructional materials development. Of course, this can lead to lack of the learners' achievement and motivation in learning English.

In attempt to increase the students' motivation to study English, there is an immediate need for providing them with appropriate materials in their studies. The students need materials which integrate their content subject with the language they are studying. The integration is intended to develop academic knowledge and skills of the students in their major content subject while they acquire the academic language needed to succeed in the university level. To be more specific, the materials needed by the students are authentic texts. The texts can be from books, magazines, newspapers, journals and others, which are usable and focus on the materials studied by the students. It is hoped that the students are able to update their specific knowledge in their specific area and have better understanding of their subject matter.

There is not an appropriate reading material at UIN Mataram; therefore, a set of appropriate instructional material for the students of Economics Department needs to be developed. The students need the material which fit their specific subject area. It is assumed that the

use of materials from the student's content subject would motivate the students to learn English because of the relevance to their course of study.

B. Statement of the Problem

Reading material is one of the learning component that should be prepared by the teacher or institution to make the teaching and learning activity run well and achieve its purpose. It is also a necessary and significant tool needed to promote and improve the students' performance. According to Nwachukwu, instructional materials are the devices developed to assist teachers in transmitting, organized knowledge and attitudes toward learners within an instructional situation.¹³ Abdul-Raheem adds that instructional materials are very important and necessary tools in improving the teacher's efficiency, the learner's performance, and make the teaching and learning interesting, practical, and realistic.¹⁴

In English Language Teaching (ELT) context, Omabe asserts that instructional materials are central in the teaching and learning of English language because they are used to compliment efficiency of a teacher and effectiveness in the delivery of a lesson.¹⁵ In addition, instructional materials, which are closely associated with EFL teachers' and learners' attitudes to the language learning process, are likely to affect their affective and cognitive involvement in the process and in turn the success level in EFL¹⁶ Hence, instructional

¹³ C E Nwachukwu, "Designing Appropriate Methodology in Vocational and Technical Education for Nigeria," *Nsukka-Nigeria: Faladu publishing company* (2001).

¹⁴ B O Abdu-Raheem, "Availability, Adequacy and Utilization of Social Studies Instructional Materials in Ekiti State Secondary Schools," *Journal of Current Discourse and Research* 3, no. 1 (2011): 242–255.

¹⁵ C C Omabe, *Instructional Materials for Social Studies Education in Nigeria, Abakaliki: Willy Rose and Apple Seed Publishers*, 2006.).

¹⁶ Badr Allehyani, Dave Burnapp, and Janet Wilson, "A Comparison of Teaching Materials (School Textbooks vs Authentic Materials) from the Perspective of English Teachers and Educational Supervisors in Saudi Arabia,"

material is highly needed in the teaching and learning process and there should be an effort from the teachers to make it available. Furthermore, Instructional materials should be well-prepared because the success of the teaching and learning process is often determined by the availability of the material. In connection with this, the teachers can design or develop themselves the materials or get the ones which have been available on the market according to the needs of the learners. When the teachers develop themselves the teaching materials, it is expected that they will be able to produce qualified instructional materials which meet the criteria for developing a good educational product.

The main problem in this study is that there is no an appropriate reading material for the the teaching of English especially reading comprehension materials at UIN Mataram. The existing material is not in accordance with the needs and characteristics of the students. Because of that, it is necessary to develop materials which can fulfill the needs and characteristics of the students and provide a way out for the improvement of the quality of English language teaching and learning in UIN Mataram. It is expected that the materials developed can motivate and help the students in learning English better. Based on the information so far mentioned, the following question is proposed:

“What reading comprehension materials are appropriate to be developed for the students of Economics Department at UIN Mataram?”

C. Objective of the Study

The success of achieving what we want to achieve in an instructional situation depend on the suitability of the teaching materials, adequacy and effective utilization of the materials. Besides,

the effectiveness of instructional materials in promoting students.¹⁷ academic performance in teaching and learning is indisputable. Providing students with the reading materials that suit their needs and characteristics is important to increase the motivation and interest of the students in learning English. This is also one way to solve the learning problem that has existed at UIN Mataram.

In general, this study is to give contribution to reading comprehension materials for the students of UIN Mataram. Specifically, this study has significance for teachers, students and the institution. Teachers can work on the materials developed to bring students into interesting class sequences in which the students can gain some enjoyment from the materials they are studying. Students can be motivated to study the material developed in order to achieve the goal stated in the curriculum. The institution can use the product developed as a model of reading materials that can be used to teach the students of UIN Mataram.

Specifically, the aim to be reached in conducting this study is to develop appropriate reading comprehension materials for the students of UIN Mataram so that they can study what they really need to learn. This Research and Development project produced an English textbook that is relevant to the objective of curriculum and the needs of the students. It is expected that lecturers and the students can take advantages of the product developed. The scope of the study is restricted to the development of reading comprehension materials that fulfill the needs of the students of Economics Department at UIN Mataram. The materials are used to teach the students to read and to comprehend texts as well as to do other activities which follow the texts.

This study dealt with materials development namely materials that match a systematic instructional design of reading

¹⁷ Alabere Rabiati Ajoke, "The Importance of Instructional Materials in Teaching English as a Second Language," *International Journal of Humanities and Social Science Invention* 6, no. 9 (2017): 36–44.

comprehension course for students of at UIN Mataram. Thus, the product of this study is an English coursebook containing reading comprehension materials, which is designed according to the needs and characteristics of the students and the goal stated in the curriculum of UIN Mataram. The coursebook provides materials for, and promotes the skills of reading. Further, the materials are composed of texts or passages taken from some authentic sources namely reading books and newspapers, which are relevant to the content subjects of the students. They consist of topics, texts, lists of vocabulary, comprehension questions, integrated skill tasks, vocabulary tasks, grammar reviews, and grammar tasks to train the students.

D. Method

1. Research Design

As this study deals with the development of reading comprehension materials, the design of this study is categorized under research and development (R&D). Seel & Richey argues that development is the process of translating design specifications into physical form.¹⁸ Soenarto defines development research as a process for developing and validating products to be used in education and learning.¹⁹ Furthermore research and development is a type of research that is done to bridge the gap that often occurs between educational research and educational practice.²⁰ Therefore, this type of research is often used to solve practical problems in education. In addition, Borg and Gall states that R&D is a process used to develop

¹⁸ Barbara B Seels and Rita C Richey, *Instructional Technology: The Definition and Domains of the Field* (Washington D.C: Association for Educational Communication and Technology, 1994).

¹⁹ Soenarto, *Metodologi Penelitian Pengembangan Untuk Peningkatan Kualitas Pembelajaran* (Jakarta: PPTK dan KPT, 2005).

²⁰ Dian Erlina, Ilza Mayuni, and Sabarti Akhadiah, "Whole Language-Based English Reading Materials," *International Journal of Applied Linguistics and English Literature* 5, no. 3 (2016): 46–56.

and validate educational products. The steps of this process are usually referred to as the R&D cycle which consists of studying research findings pertinent to the product to be developed, developing the product based on these findings, field testing it in the setting where it will be used eventually, and revising it to the correct the deficiencies found in the testing stage.²¹ This is in line with Ary et al. who state that research and development (R&D) does not formulate or test theories, but it develops effective products such as materials, media, and management systems.²² Thus, the final product developed and produced from this study is an English teaching material for the students of UIN Mataram. The objective of R&D is to produce a complete product that can be used effectively in educational program. The products of R&D can be textbooks, audiovisual materials, training manual, equipment, and many others. In relation to the aim to be reached in this study, the final product of this study is a textbook namely reading comprehension material for the students UIN Mataram.

2. Research Instrument

The instruments used in this study were questionnaire, interview, discussion, and consultation. For the purpose of collecting the data about the needs of the students, questionnaire and interview were used. The data gathered from these instruments was used as the basis to develop the materials. To collect the data about evaluation, comments, and suggestions of the experts on the developed materials, questionnaire, discussion and consultation were used. The data collected from these instruments were used as the basis to make revision of the developed materials. Whereas, in order to collect the data about the try-out, questionnaire and interview were used. The

²¹ Meredith Damien Gall, Walter R Borg, and Joyce P Gall, *Educational Research: An Introduction* (London: Longman Publishing, 1996).

²² D Ary, L Jacobs, and A Razavieh, "Introduction to Educational Research" (Canada: CBS Colledge Publishing, 1985).

data from these instruments were also used to revise the developed materials.

3. Data Collection

The instruments used to collect the data in this study were observation, questionnaire and test. Observation was conducted to elicit information about the English teaching and learning situation using the existing instructional materials in the preliminary study. Questionnaire was used to collect information about needs and performance of the students in learning English, evaluation, comments, and suggestions pertaining to the validity of the instructional material developed, and responses regarding the practicability of the instructional materials developed in the teaching and learning activities. To identify the students' needs and performance in learning English, three hundred students and five lecturers of UIN Mataram were involved in this study. To assess the validity of the instructional materials developed, two experts; design and content experts were involved. To assess the practicability of the instructional materials developed, sixty students and one lecturer as a collaborator were involved. Test was given to gather information about the achievement of the students in learning English related to the effectiveness of the instructional materials developed in the teaching and learning activities. Tests were given before and after the teaching and learning process as a part of the experimental activity in this study.

4. Types of Data

In this study, the data collected were classified into three: (1) the data collected from the needs analysis, (2) the data obtained from experts in the validation process, and (3) the data gathered during the try-out process. The first data was used as the basis to develop the materials. The second data concerned with the evaluation, comments, and suggestions of the experts on the design of the materials, content

of the materials, and the model of development of the materials. The third data dealt with the applicability of the developed materials which involved readability of the text, the clarity of the content of the materials, the clarity of learning, instruction, attractiveness, language, tasks, etc.

5. Data Analysis

Concerning data analysis, the data in the needs analysis, in the expert validation, and in the field try-out were analyzed descriptively. The data gathered from questionnaire and interview in the needs analysis was analyzed to describe the actual needs in the target situation and it was used as the basis to develop the materials. The data gathered from questionnaire, discussion, and consultation in the expert judgment was analyzed to describe evaluation, comments, and suggestions of the experts on the developed materials and it was used as the guidance for revising the materials. Furthermore, the data from questionnaire and interview in the try-out was analyzed to describe the applicability in terms of clarity, difficulties, effectiveness, usefulness, and attractiveness of the developed materials and it was used to make revision.

6. Procedure of Development

The procedure of development is a method or step that should be followed in the implementation of research and developmental strategies, in this case, educational products. Specifically, it contains the steps or stages that need to be taken by course designers in designing or developing a product. It also includes selecting or determining the kinds of model used in developing the product.

In this study, the the development of materials adopted a model from Dick and Carey which is based on the research on the process of instruction and followed by elaborating steps, starting with analysis and ending with judgment and revision of the instructional

design system using certain procedures.²³ This model consists of ten steps:

- (1) identify an instructional goal
- (2) conduct an instructional analysis
- (3) identify entry behaviors and characteristics
- (4) write performance objectives
- (5) develop criterion referenced test items
- (6) develop an instructional strategy
- (7) develop and select instruction
- (8) design and conduct the formative evaluation
- (9) revise instruction
- (10) conduct summative evaluation.

As stated earlier that the model of instructional design to be used to develop material in this study was the Dick and Carey System Approach model (1990) which had been adapted before. There were some considerations behind the application of the model of Dick and Carey in this study, some of which are the followings:

- (1) the model is not only based on the theory and the result of the research, but also the experience.
- (2) the model is designed using a system approach which enables to integrate all variables which influence learning.
- (3) the model has detailed and complete steps in comparison to other models.
- (4) the model can be used to establish instructional goal within the four domains of learning: intellectual skills, psychomotor skills, verbal information and attitudes.

However, it is also important to note here that the development of materials in this study did not completely follow the model as described above. The model was adapted or modified according to needs of the students. The steps includes the followings.

- a) need nalysis
- b) conduct an instructional analysis

²³ Dick, Carey, and Carey, *The Systematic Design of Instruction. 6th.*

- c) analyze learners and contexts
- d) developing instructional materials
- e) expert judgment
- f) revision of the instructional materials
- g) try-out of the instructional materials
- h) revision of the instructional materials

The details of reading instructional material development procedure using the the adapted or modified model are the followings.

a. Needs Analysis

The first step to be followed was to do needs analysis. In this step, the reseacher carried out needs and performace analyses to know what the students expect to learn. In the needs analysis, the researcher identified the characteristucs of the students and competencies needed by the students. Meanwhile, in the performance analysis, the researcher identified the students' knowledge, skill, motivation, and the problems faced by the students in learning English at UIN Mataram. The results of needs and performance analyses were then used as the basis for designing and developing the English reading instructional materials in this study.

b. Conduct an Instructional Analysis

After identifying the students' needs, the next step was to determine the procedures of learning to achieve learning goals. This can be done through observation, interview, and many more that focus on specific skill and learners' knowledge base. Here, there would be a decision about the skills and knowledge needed by the students to be included. Also, the domain in which the instructional goals would be adressed; cognitive, affective, psychomotor, etc.

c. Analyze Learners and Contexts

In this step, the researcher conducted audience research to determine the learner's behaviors, traits, personal preferences, and motivation factors, such as what has prompted the students to enroll. It also dealt with determining prior skills to instruction, prior knowledge to the topic, attitudes toward content, and so forth. Thus, the focus was on the characteristics that pertain directly to the goals and objectives of the course.

d. Developing Instructional Materials

After analyzing learners and context, the researcher started to develop a product of this research, namely English reading comprehension instructional materials for the students of UIN Mataram based on the results of needs and performance analyses that had been done previously and the objectives that have been set in the previous step. The materials here are the content the students use to achieve the objectives facilitated by the teachers.

e. Expert Judgment

In this stage, validation was conducted by engaging two experts (i.e. reading expert and content expert) to evaluate and give comments and suggestions whether the developed material had met the criteria of a good educational product that had been set for the purpose of developing reading comprehension materials and whether the content to be presented on the developed materials had been appropriate or suitable to the student's field of study. The experts could also evaluate using their criteria for validating the developed material. Concerning expert judgement, decision of who would be the validators of the developed materials was very important. The determination of the experts or validators in the validation process considered several things, such

as experience, knowledge, competence, background, attention, and interest of the experts.

f. Revision of the Instructional Materials

Revision was the next step to be done after the instructional materials developed (reading comprehension materials) were evaluated by the experts. Concerning with this, revision was made after the experts evaluated the reading materials in the forms of comments and suggestion. In other words, revision in this step was done based on the experts' evaluation of the reading materials.

g. Try-out of the Instructional Materials

The next stage to be followed after revising the instructional material was try-out of the instructional materials developed., The purpose of try-out was to see whether the developed materials had met the criteria of a good educational product that had been set for the purpose of developing reading comprehension materials or not, whether the developed materials were suitable for the users or not, and whether the developed materials had achieved the objectives or not in attempt to solve the learning problems. Because the developed materials in the expert validation process indicated that they did not match with the criteria, the revision was done, and then the revised materials were tried-out. Try out was intended to get feedback whether the developed material had been fixed or need to be revised. Further, try-out was intended to collect data about the applicability of the material in terms of the level of difficulty, usefulness, effectiveness and attractiveness, and to point the area of difficulties or problems that need to be revised. Try-out was conducted by giving the students and the colleague lecturer the developed materials to be studied and by asking them to evaluate and give comments and suggestions on the developed material during the try-out process. In addition, the colleague lecturer was assigned to observe the learning and teaching process during the try-out class. Finally, the developed

materials were revised again since the data in the try-out process indicated that there were still weak points on the developed materials. The try-out of the developed materials in this study was conducted in the form of small group try-out or limited try-out. After the developed materials had been revised based on the experts' judgments, the following to do was to conduct small group try-out or limited try-out which had the purposes of (1) identifying and omitting the glaring mistakes in the materials such as mistyping, (2) judging the clarity of the content of the materials, (3) identifying the easiness and difficulties in understanding and comprehending the content of the materials, and (4) judging the effectiveness, usefulness, and attractiveness of the materials. The subjects of the try-out were students of UIN Mataram. In line with this, a number of fourth semester students of UIN Mataram were selected to be a representative and they were involved in the try-out process.

h. Revision of the Instructional Materials

Revision of the developed materials was based on the evaluation, comments, and suggestion from the experts and the students. In this study, revision was necessary to make since the data collected during the expert validation indicated that the developed materials did not match with the criteria set for the purpose of developing reading comprehension materials and the data gathered from the try-out of the revised materials still indicated difficulties or problems experienced by the students to achieve the objective stated in each unit of the materials. Thus, revision was made based on the result of expert validation and try-out of the materials.

CHAPTER II THE NATURE OF READING

A. Definition of Reading

Reading is one of the skills students should acquire. It is becoming important for the people who live in the globalization era, especially in the field of academic which requires teachers and students to read a lot of information in the process of transferring knowledge. Thus, reading is an essential skill for everyone, including students and teachers. According to O'Dell what is important in reading is to be able to understand the general meaning of what readers read, and to be able to select the little bits of specific information that are important for the readers.²⁴ In line with this, Jeffries and Mickulecky states that reading is very important since it helps the readers learn to think in English, enlarge the reader's vocabulary, improve the reader's writing, practice the reader's English, prepare the readers if they want to study in an English speaking country, and find out about new ideas, facts, and experiences.²⁵ Harmer adds that there are some reason why reading is important. First, reading gives many illuminations for the student's learning. The students will get new vocabulary, known the grammatical rules and many others thing in improving the languages. Second, reading some text also invites the student to get more information and they recognize the clause, phrase and sentences in the text progress in reading fluency. Therefore, reading is really important for the students to absorb information and improve linguistic knowledge of the students.²⁶

People have their own way of defining what reading is and still many of them make a wrong definition. In general, reading is a

²⁴ Felicity O'Dell, *English as a Foreign Language. Preliminary Examinations* (London; New York Longman, 1987).

²⁵ Beatrice S. Mikulecky and L. Jeffries, *More Reading Power* (USA: Longman, 1996).

²⁶ Jeremy Harmer, *How to Teach English*, 2007.

transaction between the text and the reader. As students read, they search for and construct meaning based on what they bring to the text and what the text bring to them. According to Searfoss and Readance, reading is a process which involves an active constructing and making meaning from print. Reading is much more than recognizing words on page. Learning the meaning and function of words in reading is naturally basic, but the readers must also understand those words in context.²⁷ In addition, Rumelhart says that reading is a process of understanding a written language. Because it is a process of understanding the written language, it starts from viewing the linguistic surface representation and ends with certain ideas or meaning messages intended by a writer.²⁸ The concept above implies that the text is composed of units of written language containing certain message or meaning the writer wants to convey to the reader. Next, Cooper states that reading is a strategic process by which readers construct meaning to a text by using the clues in the text and their own prior knowledge.²⁹ These imply that reading is a process of constructing meaning from written text; the reader interacts with the graphic symbols that represent language, his language competence and his background knowledge. Furthermore, Brown states that reading is a process of negotiating meaning. The reader brings to the text a set of schemata for understanding it, and it takes the product of that interaction in second language teaching and learning.³⁰ Meanwhile, Nunan defines reading as a process of reconstructing meaning rather than decoding form, and the reader

²⁷ Lyndon W Searfoss and John E Readance, *Helping Children Learn to Read* (Boston: Allyn and Bacon, 1994).

²⁸ David E Rumelhart, *Toward an Interactive Model of Reading* (New York: Academic Press, 1980).

²⁹ J David Cooper, *Literacy: Helping Children Construct Meaning* (Boston: Houghton Mifflin, 2000).

³⁰ H. Douglas Brown, *Teaching by Principles: An Interactive Approach to Language Pedagogy* (New York: Addison Wesley Longman, Inc, 2001).

only resorts to decoding if other means fail.³¹ Based on the explanation above, it can be stated that the main purpose of reading to build, create, and construct meaning from the reading text.

Students differ in their ability to read and understand the meaning of a text or paragraph. A paragraph contains information on what the paragraph is about. However, understanding and comprehending the idea of a paragraph is not an easy matter. Since students have problems in comprehending a reading text, it is necessary for a teacher to identify those problems and provide certain strategies to help the students understand what they read. In line with this, Alexander states that the teaching quality, particularly approach, strategy and techniques are important for facilitating learning and it is the teacher who decides which approach, strategy as well as techniques to apply; he is responsible for creating a conducive classroom situation to achieve optimal learning. In short, how reading should be taught should be the main concerns of the teacher.

B. Purpose of Reading

The reader's purpose plays an important part in determining the kind of reading they do. Different persons may read the same book in different ways, because their purposes vary. The readers establish their purposes by thinking and by asking question about what they plan to read. Comprehension and speed vary according to the reader's purpose. It is important to read with purpose. It helps to understand more what is read by people. As we know that the purpose of reading is to get the meaning from the written symbol. One of the most important tasks on the reader is to find out what the writer said. There are two basic purposes of reading ability, namely the followings.

³¹ David Nunan, *Second Language Teaching & Learning*. (USA: International Thomson Publishing Company, 1999).

a. Reading for information

It is reading to study for goal such as to obtain factual information and solve problem.

b. Reading for pleasure

It is reading for enjoyment which may vary in to follow our favorite sport, comics, article, fairy tale and movie program.

Meanwhile, according to Hood, reading purposes can be classified into four, they are:

a. Reading to search for simple information and reading to skim

It is the common reading ability, here the readers scan the text to find out a specific piece of information or a specific word. Meanwhile, reading to skim is the strategy to form the general idea using basic reading comprehension and guesses the important point.

b. Reading to learn from text

It happens in an academic and professional context, it also requires remembering the main idea and the supporting idea, making a relation with the reader's knowledge. This activity could bring stronger inference because it is to help remember information.

c. Reading to integrate information, write, and critique text

This skill needs critical evaluation where the reader integrates and decides the information that she or he wants. Then, it involves abilities such as composing, selecting, and making critiques from the material.

d. Reading for general comprehension

It can be done by fluent readers very fast and automatically in the processing word, and effective coordination in many processes of the text.³²

³² Philip Hood, "Teaching and Researching Reading (2002). William Grabe and Fredericka L. Stoller. London: Pearson Education Longman. Pp. 291. ISBN 0-582-36995-9. 14.99 (\$21.95)," *Reading in a Foreign Language* 14, no. 2 (2002).

Every people who read the texts because they wanted to get something from the writing; facts, ideas, enjoyment even feelings of family community (from a letter): whatever it was, they wanted to get the message that the writer had expressed.³³ Even though our reading is just for spending time, it is still a purpose. In this case, the purpose of reading is for pleasure. It is different when we read a textbook or a recipe. We read it because we need information. In this case, our reading is to get information. Harmer divided the purpose of reading into two general purposes. First, reading for pleasure. It means that people reading material is interesting, such as magazines, comics and novel. Second, reading for usefulness of the text. People read because they need the information contained in the text, likes book, newspaper, encyclopedia, etc.³⁴

People read for different purposes. According to Nutall, it is accepted that the way people read is influenced by their purpose in reading. People read to get something from the writing such as facts, ideas and enjoyment. People also read to connect the ideas on the page to what we already know.³⁵ When the teacher trains the students to read, one of the functions of the teacher is not only to persuade them of the advantages of skimming and scanning, but also to make them see that the way they read is vitally important. In <https://www.managementstudyhq.com/purpose-and-process-of-reading.html>, it is stated that before actually beginning to read, it is important to know the purpose of reading, that is, why the reading is being done. Knowing the purpose greatly enhances the effectiveness of the reading. Also, knowledge of the purpose can help one adopt a style of reading best suited for the purpose. Some of the reasons why people usually read are to get pleasure and enjoyment, to do practical application, to obtain an overview, to locale specific information, to

³³ Christine Nuttall, *Teaching Reading Skills in a Foreign Language* (London: Heineman Educational book Ltd., 1989).

³⁴ Harmer, *How to Teach English*.

³⁵ Nuttall, *Teaching Reading Skills in a Foreign Language*.

identify the central idea or theme, to develop a detailed and critical understanding.³⁶ Therefore it can be said that reading is an activity with a purpose and it is not surprising that many people are smart and successful because they have a high interest in reading.

C. Benefits of Reading

Reading is an activity which has a lot of benefits. According to Gillet and Temple, the benefits of reading are the followings.

1. Reading Reduces Anxiety

2. First, it turns out that reading can reduce anxiety. So for those learners who are anxious about love and life's problems, you can use this method. The context of reading in this case can be broad. It can be interpreted that reading the holy book (according to your religious teachings) can also be any book.

3. Reading Makes the Brain Develop

The second benefit is that our brains are much more developed. It's different when the brain is accustomed to reading. The feeling is that the brain is more active in thinking and is trained to do small analyses. At least this little habit will affect you in spilling ideas, speaking words, and so on. At least your way of thinking is clearer and more developed. The habit of thinking analytically also stimulates the brain to be more open to receiving opinions and knowledge from others. One indication can be seen that you often learn from the experiences of others, rather than blaming other people or making up other people's mistakes.

4. Reading Increases Knowledge

Reading is effective in increasing your knowledge. Not only that, your brain is better at remembering things too. Every time you have a problem or problem, you can use the knowledge you have to solve the problem that is right in front of you.

³⁶“<https://www.Managementstudyhq.Com/Purpose-and-Process-of-Reading.Html>.”

5. Reading Helps to Become A More Thinking Person

The fourth benefit of reading is to help you become a simple thinker in dealing with problems. People who have good thinking skills have their ways and solutions. Where the solution decision is taken as a reflection that there are many simple solutions. Problems should be addressed wisely, easily, and not overly thought. Or what we more familiarly call an attempt to simplify the problem. Unfortunately, not everyone can simplify their problems. That is why many people are stressed but they are not aware of their stress. Many also end up running away, which in my opinion is a symptom that there is a problem that cannot be treated.

6. Reading Serves as A Comforter

For some people, the benefits of reading books are not only to broaden their horizons but also to find fun, entertainment or enlightenment from any existing problems. Moreover, humorous books, novels, or books that are interesting but funny will make readers feel entertained. At least smile yourself with the book he is holding.

7. Reading Improves Memory

Reading will train the brain to stay active, the cells in the brain will be active and get used to seeing something new (words) in a fast time. At the time of reading, we will read the words in a short time right. That's where we will test our memories that we will memorize them by ourselves even though we don't memorize them. Memorize or not, depending on the abilities of each person. Some people read it once, they immediately understand and memorize it. Some people have done it six times but have not memorized it.³⁷

³⁷ Jean Wallace Gillet and Charles A. Temple, *Instructor's Manual to Accompany Understanding Reading Problems: Assessment and Instruction* (Little Brown, 1986).

D. Models of Reading Proces

Constructing meaning from the text is the main objective of a reading activity. How a reader translates print to meaning is the key issues in the building of models of reading process. There are three processes of reading: the bottom up process, the top down process, and interactive process.

1. The Bottom up Process.

The bottom up processing views influenced by structural linguistics and behaviorist. This view assumes that reading comprehension is a process that involves exact, detailed, sequel perception identification of letters, word, spelling pattern or larger language.³⁸ Furthermore, Vacca *et al.* states that the process is initiated by recognizing letters, words, then proceed to sentences, paragraphs, and text.³⁹ Thus, based on this approach reading is a process of finding the meaning of written symbols, from the smaller units to larger ones and we need certain strategies to find the meaning of written form in order to arrive at meaning. Stated in another word, we need certain strategies to find the meaning of written languages.

2. The Top down Process

Goodman states that in the top down processing view, the reader's cognitive and language competence pay the key role in the construction of meaning from the text. This view believes that the meaning is not the characteristics of text because texts are constructed by authors to be comprehended by readers and thus the meaning is in the author and the reader.⁴⁰ According to Vacca,

³⁸ K. Goodman, *Interactive Approaches to Second Languange Reading* (New York: The Process Syndicate of the University of Cambridge, 1998).

³⁹ Mary Gove et al., *Reading and Learning to Read* (New York: Harper Collins Publisher, 1991).

⁴⁰ K. Goodman, *Interactive Approaches to Second Languange Reading*.

et al., this process is initiated by making predictions about the meaning of some unit of the text.⁴¹

3. The Interactive Process.

According to interactive process view both bottom up and top down processing are interactively available to process and interpret the text. This process is initiated by formulating hypothesis based on the interaction of information from semantic, syntactic, and graph phonic of information.⁴² Efficient and effective reading requires both bottoms up and top down processing operation interactively.

E. Types of Reading

According to Patel and Praveen, there are some types of reading such as intensive reading, extensive reading, aloud reading and silent reading.⁴³

1. Intensive Reading

Intensive reading is a type of reading that focus on idiom and vocabulary that taught by the teacher in the classroom and that idiom and vocabulary is exist in poem,poetry,novel or other source. For example: The students focus on linguistic or semantic details of a reading and focus on structure details such as grammar.

2. Extensive Reading

Extensive reading is a type of reading which involves learners reading texts for enjoyment and to develop general reading skills. For example: the students read as many different kinds of books such as journals, newspapers and magazine as you can, especially

⁴¹ Gove et al., *Reading and Learning to Read*.

⁴² Ibid.

⁴³ M F Patel and Praveen M Jain, *English Language Teaching* (Jaipur: Sunrise Publishers and Distributors, 2008).

for pleasure, and only needing a general understanding of the contents.

3. Aloud Reading

Aloud Reading is reading by using loud voice and clearly. For example: reading poetry, dialogue, and other type of texts.

4. Silent Reading

Silent reading is an activity meant to train the students to read without voice in order that the students can concentrate their attention or thought to comprehend the texts. For example: the students reading a text by heart.

F. Principles Behind the Teaching of Reading

Principles of teaching reading are generalization about reading instruction based on research in the field of reading and observation of reading practices. They are the ones we believe useful in guiding teachers in planning reading instruction. According to Harmer, there are some principles underlying the teaching of reading, namely the following.⁴⁴

1. Reading is not a passive skill

Reading is an active occupation. To do it successfully we have to understand what the word mean, see the pictures the words are painig, understand the argument and work out if we agree with them

2. Students need to be engaged with what they are reading

Students who are not engaged with the reading text will not be actively interested in what they are doing. They are less likely to benefit from it. When they are really fired up by the topic or the task, they get much more from what is in front of them.

⁴⁴ Harmer Jeremy, *Teach English* (London: Longman, 1998).

3. Students should be encouraged to respond to the content of a reading text, not just to the language

It is important to study reading text for the way they use language, the number of paragraph they contain. But the meaning, the message of the text is as just as important and we must give students a chance to respond to that message is some way. It is important to allow them to express their feeling about the topic to provoke personal engagement with it and the language.

4. Prediction is a major factor in reading

When we read text in our own language, we frequently have a good idea of the content before we actually read. Book covers give us a hint of what is in the book, photographs, and headlines hint at what articles are about Teachers should give students hints so that they can predict what is coming too. It will make them better and more engaged readers. Match the task to the topic. Once a decision has been taken about what reading text the students are going to read, we need to choose good reading tasks. In this case we should give them the right kind of questions, engaging, and useful puzzles.

5. Good teachers exploit reading text to the full

Any reading text is full of sentences, words ideas, description, etc. It doesn't make sense just to get the student to read it and then drop it to move on to something else. Good teachers integrate the reading text into interesting class sequences, using the topic for discussion and further task.

The five principles behind teaching reading propose some important points that need to be considered by the teacher in teaching reading, such as it is important to make the students engaged with and have the abilities to respond to the texts. The principles also highlight that predicting is crucial in reading since it is related to the students' active process of reading. In addition, choosing the good tasks is one of the considerations to make the reading activity be more exciting and challenging. By referring to

those principles, the teacher and students can be facilitated to attain a good-quality of reading process.

Furthermore, Anderson in Nunan mentions eight principles for the teaching of reading.⁴⁵ The principles are the following:

1. Exploiting the reader 's background knowledge

Students' background knowledge should be activated to be able to comprehend texts. Anderson in Nunan says that background knowledge is any experiences that readers have that will be connected with what they face in texts, for example, life experiences, educational experiences, cultural background and knowledge, knowledge about the language itself, and so on. By activating and developing students' background knowledge, it is easier for students to comprehend texts. Activating background knowledge can be done by asking questions, making predictions, and the like. But the teacher has to make sure that at least the students have the correct background knowledge. Incorrect background knowledge can obstruct students' ability to comprehend texts well.

2. Building a strong vocabulary base

English teachers in Indonesia often found their students having difficulty in mastering vocabulary. Sometimes when students read, they may find some unfamiliar words in which they do not know what the meanings are. Because of this obstruction, they cannot comprehend the text. The reading process is stuck in where the unfamiliar words come out. Most of them still cannot find meanings from the text itself. The familiar thing that often happens is that students do not even try to find the words from their dictionary. That is why teachers should teach vocabulary that students might encounter in the text explicitly. Students also need to be taught how to find meanings of unfamiliar vocabulary from the text itself.

⁴⁵ David Nunan, *Practical English Language Teaching First Edition* (New York: Mcgraw Hill, 2003).

3. Teaching for comprehension

English teachers should teach students how to really comprehend texts, not just focus to test students' reading ability in comprehending. Sometimes, students can do reading tests without really comprehending the texts they read. It means the process of comprehending texts is not successful. That is why the teachers should focus more on the process of students' comprehension rather than the result of their comprehension.

4. Working on increasing reading rate

Teachers have to help students to increase their reading rate because the slower students read, the slower they comprehend the texts. It means that their reading rate affects their ability in comprehending texts. Sometimes, teachers find students keep stuck in reading because they have to look up some unfamiliar vocabulary in the dictionary. Teachers have to help students to reduce their dependence on a dictionary by teaching them some skills like scanning, skimming, and the like which let students increase their reading rate.

5. Teaching reading strategies

One of the principles that should be known by teachers is teaching reading strategies to students. Teachers should realize that students have their characteristics in reading and comprehending texts. Teachers can observe students or have a talk with them about how they read or what difficulty they find during reading. By knowing that, students can be suggested to have their own suitable strategy so they can read and comprehend texts easier.

6. Encouraging readers to transform strategies

After having students find their best strategy in reading, the teachers can implement activities that let students do the activities of reading with their own strategy. This way lets students easier to read and comprehend texts because they have been familiar with the strategy applied.

7. Building assessment and evaluation into the teaching

Students' reading should always be monitored and assessed. Assessing students' reading is not merely testing their comprehension, but assessing the process of their reading. According to Anderson in Nunan, the assessment in teaching reading can be divided into two categories, namely quantitative and qualitative assessments

8. Striving for continuous improvement as a reading teacher.

Another important principle that should be known by English teachers in teaching reading is keeping themselves to improve their works. The teachers should never feel bored in teaching. They have to be passionate. They should find various ways to make sure the students can read and comprehend texts. And the most important is to make students enjoy reading by themselves. Teachers can find various texts which interest the students, apply new techniques or media in teaching in the classroom, and so on.

From the explanation above, it can be concluded that teachers need to understand and implement eight principles in teaching reading. As stated before, it is important to consider the background knowledge, the vocabulary foundation, the comprehension, the reading rate, the reading strategies, the students' transformation strategy, the assessment and the evaluation, and the last, the teachers' improvement for teaching reading. By implementing these principles in the teaching and learning process, teachers can teach reading and make sure the process runs well.

Finally, a good teacher should be familiar with the principles so that he can determine an appropriate strategy to help the students achieve their goal in reading. Beside that, the teacher should make the students aware that reading needs strategy in order to arrive at the meaning or the message of the text being read.

G. Theories Underlying Reading Instruction

Cahyono and Widiati by extracting a number of experts elaborate some theories underlying reading instruction. They explain that the text, the reader, and the interaction of the text and the reader, which make up the three reading models, have offered insights in how reading should be taught. The importance of the text in facilitating reading signifies the importance of the text structure theory. The role of the reader's prior knowledge in understanding messages in a reading text is the emphasis of the schema theory. The interaction of the reader and the text has been the focus of the metacognitive theory. These theories constitute the most prevalent theories underlying reading instruction. The three theories are the following.

1. The Text Structure Theory

According to the theory of text structure, a text has a structure. The structure of a text resembles a tree structure, where the more general information subsumes the more specific information in the text. Accordingly, the location of information in a text structure relates to the level of ease in remembering the information. Information which is more general (which is located in the upper level of the structure) is remembered more easily than the more specific information (which is located in the lower level of the structure).

When reading, a reader tends to select information which is more general than the more specific one. This is because a better understanding of the main idea will lead to the easier understanding of the peripheral ideas in the text. Research has shown that reading instruction which is based on various aspects of text structure is effective in improving students reading comprehension in second language. For example, the teaching of the information at the upper-level of text structure significantly increases the information that could be retained by second language students. The teaching of

concept mapping (i.e. a diagram showing a relation of general information and its detailed information) helped students identify key ideas in a text which, in turn facilitates them in comprehending information in social and exact science textbooks.

2. The Schema Theory

Understanding a piece of discourse involves much more than just knowing the language. A potential reader comes to read a text with something in his or her mind or memory, which is called schema, which means pre-existent knowledge of the world. A schema refers to a structure of data which represents generic concepts stored in memory. A schema contains interrelated concepts which are stored in a hierarchy, where the more general concepts subsume the more specific ones. The concepts could be in the forms of objects, situations, sequence of events, actions, and sequences of actions. In other words, a schema represents a pre-existing structure in the reader's mind which organizes his or her knowledge of the world. In the process of comprehension, schemata construct an interpretation of concepts in the text someone is reading. There are three kinds of schemata: linguistic schemata (i.e., prior linguistic knowledge), content schemata (i.e., prior background knowledge), and formal schemata (i.e., knowledge of text structure).

In the area of reading instruction, schema theory, which studies background knowledge that facilitates text comprehension, has a great number of supports. For example, both native and non-native readers were likely to bring similar prior knowledge when reading a text with a universal theme. However, they showed differing degrees of previously-acquired knowledge when reading a text of a culturally-bound theme. Research showed that the provision of hints to activate students schemata helped increase reading comprehension. One of the weaknesses that less competent readers have is the absence of relevant knowledge structures, or schemata, that can be utilized to facilitate topdown processing.

3. The Metacognitive Theory

The term metacognition refers to knowledge about or regulation of cognition (planning, monitoring, and evaluating) or thinking about one's own thinking. It also concerns learner's knowledge of and use of their own cognitive resources, which involve behaviors such as predicting, self-questioning, paraphrasing, summarizing, rereading to clarify meaning, and retelling. Thus, metacognitive theory deals with activities in prereading, whilst reading, and post-reading stages which should undergo during independent reading or in reading instruction in order to facilitate comprehension and learning.

Developing metacognitive awareness is an essential part of effective reading strategy instruction. Accordingly, effective and efficient readers are those who not only know what to read in order to comprehend a text, but also know how best to approach the text before, during, and after reading it. In a study comparing the ways skilled and unskilled readers search for the main ideas of a text, skilled reader uses metacognitive strategies in identifying and understanding main ideas. Unlike the unskilled readers who try to find the main ideas in the text, the skilled readers construct them. Furthermore, the unskilled readers rely much on topic sentences. On the other hand, the skilled readers ask questions before, during, and after reading, and they apply some strategies such as prereading, activating prior knowledge and predicting what the content and who the author is.

Reading instruction could be facilitated through various ways, such as providing advance organizer (i.e., to activate the students background knowledge) before reading, giving examples and more practice when reading, and providing feedback to students for the activities conducted in the pre-reading and whilst reading. The teachers make use of the integration of the models of the reading process in EFL/ESL reading instruction. In achieving our immediate goals in the EFL/ESL reading classroom, we must strive for an

optimum balance between the background knowledge presupposed by the texts our students read and the background knowledge our students possess. As we have shown by means of the foregoing classroom activities and techniques, this balance may be achieved by manipulating either the text and/or the reader variable. In sum, the text structure, schema, and metacognitive theories have provided us with a better understanding of how reading instruction should be based and done. These theories, which have been empirically supported, will be used as a guide in analyzing the teaching of and research on EFL reading in the Indonesian context. However, before discussing the EFL reading instruction and research in this country, the following section presents a view of how an EFL reading instruction should be approached in more details.⁴⁶

H. Teaching Reading as a Foreign Language

There are experts proposing theories of teaching reading. Farrel writes about how to prepare and present reading lesson that has a strategic focus. Moreover, reading teachers should first get a clear idea of what reading is and then decide on the kinds of appropriate instruction and lessons to offer students. Teachers should become aware of the reading process in order to be able to anticipate the types of processes and potential problems their students may experience when reading in a foreign language. Teachers then can take a strategic approach to the teaching of reading by having as their main goal to help students apply effective reading strategies independently before, during and after reading both inside and outside the classroom.

Before reading, the teachers can active what learners already know about the topic. During class reading time, teachers can emphasize students' understanding of the passage and help them

⁴⁶ Bambang Yudi Cahyono and Utami Widiati, "The Teaching of EFL Reading in the Indonesian Context: The State of the Art," *Teflin Journal* 17, no. 1 (2006): 36–58.

recall the information. After reading a passage, reading teachers can help students think about what they have read, make connection to what they already knew about the topic, get new information, and ask questions about what they have just read. So, effective reading lessons have students' active in all phases of the lesson.⁴⁷

Furthermore, Nuttall offers a broad explanation on teaching reading as a foreign language. In her book, she writes about the definition of reading, the purpose of reading, how to selecting a text for reading, how to increase and vary reading speed, how to utilize non-text information, the word-attack skills, text-attack skills, questioning, an intensive and extensive reading program in a foreign language. He adds that it is accepted that the way people read is influenced by their purpose in reading. People read to get something from the writing such as facts, ideas, and enjoyment. If none of the purposes are written in the foreign language, it may be unnecessary for us to read in the foreign language at all.⁴⁸ Furthermore, Burn et al. stresses that learning to read depends on motivation, practice, and reinforcement. Consequently, teachers must show students that being to read is rewarding in many ways, for example, telling the students that reading increases success in school, helps in coping with everyday situations outside of school, and provide recreation. Children are motivated by the expectation that they will receive these rewards, which then provide reinforcement to continue reading.⁴⁹

The main task in teaching reading is to teach understanding. To assess the problem of what to teach when teaching understanding, we must try to determine what is likely to prevent a child from comprehending a given text. In the classroom, the teacher's job to promote these tress learning process by the use of appropriate teaching act. Thus, the teacher presents and explains new material in

⁴⁷ Thomas S C Farrell, "Teaching Reading Strategies:'It Takes Time!'" (2001).

⁴⁸ Nuttall, *Teaching Reading Skills in a Foreign Language*.

⁴⁹ Paul C Burns, Betty D Roe, and Elinor P Ross, *Teaching Reading in Today's Elementary Schools* (London: Hough ton Mifflin Company, 1999).

order to make it clear, comprehensible and available for learning, gives practice to consolidate knowledge, and test. In order to check what has been mastered and what still needs to be learned or reviewed. And also, the teacher's responsibilities in helping learners achieve these goals will be to motivate reading by selecting or creating appropriate text, to design useful reading tasks, to set up effective classroom procedure, to encourage critical reading, and to create a supportive environment for practicing reading. Each learner will have different strengths to build on and different weaknesses to overcome. Therefore, there can be no signal, set, rigid methodology for reading. The teacher will need to focus on different goals at different times and to use a range of materials and tasks.⁵⁰

The students' ability to understand reading materials or lesson delivered by the teacher depends on a number of factors. In other words, there are many factors contributing to the students' reading achievement that should be taken into consideration by the teacher in the teaching of reading. According to Brown, the success of teaching and learning reading can be affected by a number of factors. In this case, there are two factors which affect the students' reading comprehension achievement, namely: internal factor and external factor.⁵¹

Internal factor means the factors which come from the reader himself. It is also known as personal factor. This factor dealt with self-motivation and interest. Motivation plays important role in comprehending the text. The learners will be motivated to read when they feel need something from the text. Brown divided the motivation theory into two kinds, namely: intrinsic and extrinsic motivation. Intrinsic motivation is intrinsically motivated activities are ones from which there is no apparent reward except the activity

⁵⁰ Tricia Hedge, *Teaching and Learning in the Language Classroom*, vol. 106 (Oxford university press Oxford, UK, 2001).

⁵¹ H. Douglas Brown, *Teaching by Principles: An Interactive Approach to Language Pedagogy*.

itself. It is aimed at bringing about curtaining internally rewarding consequence, such as feelings of competence and self-determination. While, extrinsic motivation is extrinsically motivated behavior that carried out in anticipation of reward from outside and beyond itself such as, money, grades, prizes and even certain of positive feedback. Meanwhile, interest is one of the important factors in order to increasing students' comprehension achievement in reading. If one has interest to read, it means they will get a good achievement. On the other hand, if the reader has no any interest to read, it can influence their achievement. We should know the ways to make it stay or increase with three stages: brainstorming, extending and accessing.

In addition to the factors of interest and motivation that have been described above, attitudes, reading habits, level of intelligence, and language skills are also essential factors that affect students' reading achievement. Attitudes are related to one's feelings of pleasure and displeasure towards reading activity, reading habits are related to one's reading tradition and opportunity spent for reading, intelligence levels will affect one's ability to read in which everyone has different reading ability so that the results are also different, and language skills for example, the limited amount of vocabulary a person possess, it is difficulty for him or her to understanding the meaning of what he or she reading.

External factor has a close relationship with reading material and teacher of reading. The students' achievements' in reading depends on the level of difficulty text. Hence, it can influence students' achievement if the text given is not appropriate with the level of the readers. The teacher should also be careful in choosing the text and giving an assignment due to they are related to the students' comprehension achievement.

I. Learning Reading Process

Brown defines learning as a process of acquiring or getting of knowledge of a subject or a skill by study, experience or instruction. He also breaks down learning definition into smaller components, namely:

1. learning is acquisition or getting.
2. learning is retention of information of skill in which retention implies storage systems, memory, and cognitive organization.
3. learning involves active, conscious focus on and acting upon events outside or inside the organism.
4. learning is relatively permanent but subject to forgetting.
5. it involves some form of practice, perhaps reinforced practice, and learning is a change of behavior.⁵²

From the definition above, it is apparent that learning is an activity done by human being as an effort to get knowledge, to create attitudes, and to raise concept and skills as a result of the interaction with the environment. Learning is actually related to the process of acquisition and skill or information retention in the cognitive organization. Learning can also be carried out through some form of reinforced practice. In learning process, the dominant activity is the interaction between teacher and the students.

According to Brown, teaching may be defined as showing or helping someone to learn how to do something, giving instructions, guiding in the study of something, providing with knowledge, causing to know or understand. Teaching is guiding and facilitating learning, enabling the learner to learn, setting the conditions for learning. In other words, teaching is a way of providing someone to get knowledge, to create attitudes, and to raise concept and skills. Teaching activity cannot be separated from learning. It is because the process of teaching should be based on how students learn and it will determine the teaching style, techniques, and strategies of teaching to meet the students' needs of learning.⁵³

⁵² Ibid.

⁵³ Ibid.

Comprehension skills are strategies readers use to retrieve information and construct meaning from a particular text. They are the thinking processes, broken down into steps that are used to comprehend. These must be taught explicitly. Three types of comprehension skills are described below: pre-reading, during reading, and post-reading.

Teaching reading comprehension is an activity in which the teacher guides and facilitates learning, gives a chance for the learners to learn and sets the condition for learning. Guidance is done by leading students to do activity in the effort of getting knowledge. The activity itself can be done by giving them tasks. However, an important point dealing with giving tasks to the students is about the consideration of technique used. A Teacher should consider the best technique to be applied for a particular task or activity. In teaching reading comprehension, the teacher also helps students to learn micro skills and macro skills of readings, as follows:

a. Micro skills of reading

1. Discriminate among the distinctive graphemes and orthographic patterns of English.
2. Retain chunks of language of different lengths in short-term memory.
3. Process writing at an efficient rate of speed to suit the purpose.
4. Recognize a core of words, and interpret word order patterns and their significance.
5. Recognize grammatical word classes (noun, verb, etc.), systems (e.g. tense, agreement, pluralize), patterns, rules, and elliptical forms.
6. Recognize that a particular meaning may be expressed in different grammatical forms.
7. Recognize cohesive devices in written discourse and their role in signaling the relationship between and among clauses.

b. Macro skills of reading

- 1) Recognize the rhetorical forms of written discourse and their significance for interpretation.
- 2) Recognize the communicative functions of written texts, according to form and purpose.
- 3) Infer context that is not explicit by using background knowledge.
- 4) From described events, ideas, etc., infers links and connections between events, deduce causes and effects, and detect such relation as main idea, supporting idea, new information, given information, generalization, and exemplification.
- 5) Distinguish between literal and implied meaning.
- 6) Detect culturally specific references and interpret them in a context of the appropriate cultural schemata.
- 7) Develop and use a battery of reading strategies, such as scanning and skimming, detecting discourse markers, guessing the meaning of words from context, and activating schemata for the interpretation of texts.

The micro and macro skills are in line with the strategies of reading comprehension. Thus, in teaching reading comprehension, a teacher should provide the students with three steps of reading comprehension; before, during, and after reading through to facilitate the students build the context and get the ideas of a text in order to achieve the macro and micro skills of reading.

Reading is a transaction between the text and the reader. As students read, they search for and construct meaning based on what they bring to the text and what the text brings to them. Ur states that reading skills need to be fostered so that learners can cope with more and more sophisticated texts and tasks and deal with them efficiently: quickly, appropriately and skillfully. In relation to this, it is important to develop fluent and proficient readers who are knowledgeable about the reading process.⁵⁴

⁵⁴ Penny Ur, *A Course in English Language Teaching* (Cambridge University Press, 2012).

It is important to develop fluent and proficient readers who are knowledgeable about the reading process. Effective readers are active readers who use a repertoire of comprehension strategies before, during, and after interacting with texts. Proficient readers bring their backgrounds to the reading, have a plan for comprehending a range of texts, interact with the texts (building interpretations as they read), and shape their responses based on their reading. According to Nuttall, effective readers are active readers who use repertoire of comprehension strategies before, during and after interacting with the text.⁵⁵

a. Before reading

Readers preview the text by looking at the title and the text to evoke relevant thought, memories and association. They build background by questioning themselves to see what they already know about the topic, the form in which the topic presented, and the vocabulary that might communicate the ideas about the topic. They set purpose for reading by asking themselves what they want to learn or experience by reading the selection.

b. During reading

Readers create a dialogue with the author, striving to reformulate what the author is saying. They check their understanding of the text by paraphrasing the author's words and they monitor it by imagining interring, predicting and confirming.

c. After reading

Readers summarize what they have been reading and contemplate their first impression. They reflect and take second looks to develop more thoughtful and critical interpretation of the text. Finally, they make application of the ideas encountered in the text by extending these ideas to broader prospective.

Successful language learners adapt these strategies as they construct meaning from a variety of oral, written, and visual texts and experiences. Another characteristic that distinguishes proficient

⁵⁵ Nuttall, *Teaching Reading Skills in a Foreign Language*.

readers from ineffective readers is that they read often and regularly. As they read, their reading improves. Ineffective readers often choose to avoid reading and do not develop the same love of literature or the lifelong habit of reading as a rewarding leisure-time pursuit. Teachers can make a major difference in students' success or failure to read texts effectively by modeling, coaching, facilitating, and promoting reading in their classrooms.

J. Reading Assessment

a. Types Reading Assessment

As we know that assessment is the process of gathering information to monitor progress and make educational decisions if necessary. One of the purposes of teaching English reading as a foreign language skill to the students is to encourage them to construct meanings of what they read. Assessment, as a part of teaching and learning processes, should support this purpose. The English teachers should motivate students in reading through an appropriate assessment.

Grumilah and Aji states that assessment actually is not a matter of scoring students competence. There is assessment which functions to improve students' learning, and also assessment to judge whether students are success or fail. It should be made as clear as possible of those both functions belong to which one of the assessments. To distinguish the different kinds of assessment, some experts use formal and informal assessment. formal assessments are exercises or experiences specifically designed to tap into storehouse of skills and knowledge, usually within a relatively short time limit. Formal assessment typically means using a test that involves standardized administration and that has norms and a formal interpretive procedure. On the other hand, informal assessment is a way of collecting information about our students' performance in normal classroom condition. It is formative and process oriented which

means to evaluate students in the process of forming their competence is and skills with the goal of helping them to continue that growth process.⁵⁶

Formal assessment of reading often takes the form of a test. The key for designing an assessment activity is that it must be consistent with objectives and instructional practices. It must be appropriate for the concepts and skills being taught and for the methods and processes used in teaching throughout the unit. If personal response is important, it must be reflected in the formal assessment. If several levels of questions have been used in daily work, they must be used in the final assessment activity. If key directives have been used in instruction, the appropriate vocabulary should appear on the final assessment. Teachers, as reflective practitioners, should know what, why, and how they are using tests. Teachers should ask themselves questions such as the following:

- a. have the students been taught how to prepare for and write a test?
- b. have the students been given sufficient notice and information to prepare adequately (e.g., Have they been told whether the test will be open book, essay, and short answer)?
- c. have students been taught the vocabulary of questions (e.g., compare, explain, etc.)?
- d. have students been taught how to use reference materials (e.g., dictionary, language usage handbook) during a timed testing situation?
- e. have adaptations for students with special needs been considered?
- f. have students been informed of how they are going to be graded?

Formal tests can be appropriate and useful assessment tools but, as with all classroom practices, there should be a variety of assessment techniques employed. It is important to remember that student understanding of even the most traditional literature can be

⁵⁶ Apsus Grumilah and Irfan Nur Aji, "INFORMAL ASSESSMENT FOR LANGUAGE SKILLS: THE LEARNERS' PERSPECTIVE," in *International Conference on Education and Language (ICEL)*, 2016, 81.

assessed in non-traditional ways. Formal cloze tests, standardized informal reading inventories, and other normed tests can also serve a purpose. These instruments can be used by trained personnel to determine students' strengths and weaknesses, and areas that need to be addressed. The overriding consideration is that assessment and evaluation should provide information regarding students' abilities to read various texts

The continuous informal assessment of each phase of the reading process (before, during, and after reading) directs instruction and gives teachers insight into students' interests, attitudes, needs, and existing reading strategies. Much of the evaluation in reading is diagnostic in nature. As classroom teachers observe and interact with students, they should be making diagnostic decisions which will translate into classroom practice. A variety of instruments can be used to guide the diagnosis. Early in a course, teachers can determine the interests, attitudes, and abilities of their students. Simple inventories such as the following can be used to get to know the students and to gain insights in order to guide reading. Therefore, Assessment and evaluation should reflect the program goal of promoting the interaction of students with oral, print, and other media texts. Assessment can take many forms. Although formal and standardized tests can be informative if chosen, used, and interpreted judiciously, the teacher's informal assessment can be even more useful.

b. Classroom Based Reading Assessment

O'Neil in Apsari and Haryudin states that classroom based assessment is defined as informal ways of assessing the students that emphasize on the formative assessments. Other experts defines that classroom based assessment as an alternative to conventional way of monitoring students' language progress and performances. Classroom based assessment uses activities that reveal what the students do with the language, emphasizing their strengts instead of

their weaknesses. Classroom based assessment instruments are not only designed and structured differently from traditional tests but also scored differently. Because classroom based assessment is performance based that the point of language learning is communication. Classroom based assessment involves the documentation of students performance, that is planned, collected and interpreted by the teachers as part of the instructional cycle. Therefore, it can be concluded that in relation to reading comprehension, classroom-based assessments have a greater ability to measure complex reading tasks in a contextualized setting and can provide ample information about the use of reading strategies and skills by students.⁵⁷

O'Neil in Apsari and Haryudin states that classroom based assessment is defined as informal ways of assessing the students that emphasize on the formative assessments. Other experts defines that classroom based assessment as an alternative to conventional way of monitoring students' language progress and performances. Classroom based assessment uses activities that reveal what the students do with the language, emphasizing their strengts instead of their weaknesses. Classroom based assessment instruments are not only designed and structured differently from traditional tests but also scored differently. Because classroom based assessment is performance based that the point of language learning is communication. Classroom based assessment involves the documentation of students performance, that is planned, collected and interpreted by the teachers as part of the instructional cycle. Therefore, it can be concluded that in relation to reading comprehension, classroom-based assessments have a greater ability to measure complex reading tasks in a contextualized setting and can

⁵⁷ William Grabe and Xiangying Jiang, "Assessing Reading," *The companion to language assessment* 1 (2013): 185–200.

provide ample information about the use of reading strategies and skills by students.⁵⁸

Furthermore, Cheng, Roger and Hu in Apsari and Haryudin mention three categories of methods in assessing reading., namely 1) teacher- made method, 2) student-conducted method (summarizing, journal, peer assessment, read aloud, dictation, self assessment and portfolio), and 3) non-teacher developed method (standardized reading test). Two of the three methods, teacher made method and students conducted method, are regarded as classroom based reading assessment. The description of each method will be given below.

1) The Teacher Made Method

The teacher method includes some techniques such as short answer, multiple choice, cloze, and observation. Multiple-choice questions usually consist a number of options (usually four), from which the testee has to select the right one. The multiple-choice questions are a common means of assessing learners' reading comprehension because the task is familiar to subjects and is easy for researchers to score. So far, multiple-choice test items are so popular because they provide testers with the means to control test-takers' thought processes when responding; they allow testers to control the range of possible answers. Even though it may be time-consuming to prepare a multiple-choice test, it is easy to mark, and to evaluate.

Short-answer tests are extremely useful for testing reading comprehension. In addition, they tests are seen as a semi-objective alternative to multiple choice.” Test-takers are supposed to answer a question briefly by drawing conclusions from the text, not merely by responding ‘yes’ or ‘no.’ The testtakers may be required to infer meaning from the text before answering the question.

⁵⁸ Yanuarti Apsari and Acep Haryudin, “THE ANALYSIS OF ENGLISH LECTURERS’CLASSROOM-BASED READING ASSESSMENTS TO IMPROVE STUDENTS’READING COMPREHENSION,” *ELTIN JOURNAL, Journal of English Language Teaching in Indonesia* 5, no. 1 (2017): 35–44.

Cloze tests have been widely used in language assessment, particularly for the assessment of reading skills in language tests, both in classroom and in standardized tests. Moreover, cloze tests have been shown to be the best indicator of reading ability. It is believed that cloze tests are more efficient and reliable than reading comprehension test which use open-ended questions or short answers because they are easier to evaluate and do not, as in many reading comprehension tests, depend on long written answers to evaluate. The aim of cloze tests is to evaluate readability and reading comprehension. Furthermore, cloze procedure is also used to assess reading strategies used by readers or to develop learners' reading strategies. Because some words are deleted, cloze forces readers to be more aware of the meaning and calls for the use of reading skills like scanning and searching that are often neglected in second language reading.

Observation is the most common form of classroom based reading assessment. There are different ways to conduct observation. One way is to use an observation checklist, noting which reading behavior are observed. Another ways is to keep anecdotal records. Anecdotal records not only includes the information about students reading comprehension but also the time, date setting and name of those involved.

2) Student-Conducted Method

Students conducted method is the method that the students select and direct their own learning activities in doing reading assessment. The method includes some techniques such as summarizing, free recall test and retelling. Summarizing is an academic literacy task that entails both reading and writing abilities. Summary writing is commonly regarded as a reading comprehension strategy. By completing a summary, students may become very proficient in distilling the main events from the text while actively using in context some of the key words they encounter within it. In

addition, Asking students to write summary after reading can accurately evaluate students reading ability.

In free recall test, the students are required to read the text and then to write down everything to they can remember from the text. This technique is cosidered to provide a picture of learner process. Retelling as a post reading or post listening recalls in which readers or listeners tell what they remember orally or writenly. Thus, retelling is included to one of post reading activities.The importance of post reading activities cannot be denied, for at least three reading principles which can be found in post-reading activities, namely: students needs to be engaged with what they are reading, students should be encouraged to respond to the content of the text, and student should be exploited to the reading texts to the full. In short, the main point of using post reading activities is variety, which leads to creating positive, creative, innovative, effective and fun activities.⁵⁹

⁵⁹ Ibid.

CHAPTER III THE NATURE OF READING COMPREHENSION

A. Definition of Reading Comprehension

Before defining what reading comprehension is, it is necessary to understand some theories which underly reading comprehension itself. Gilakjani's and Sabouri's elaboration about reading comprehension theories by quoting a number of experts is very helpful. They state that there are three types of theories of reading comprehension, namely mental representations, content literacy, and cognitive processes.

Dealing with Mental Representation, they elaborates that When a reader is reading a text, he can create a mental representation of the text that explains how the reader understands the text. A lot of researches supported the many levels of representation are included in constructing meaning. So far, when a reader is reading a text, three various levels of mental representation are created. They are the surface component, the text-base, and the situation model. Next, when the words and phrases and not the meaning of the words and phrases, are encoded in the mental representation, this is defined as the surface component of mental representation.

The text-base indicates the meaning of the text and is composed of those parts and connections that are arose from the text itself without increasing anything that is not clearly identified in the text. A text-base can be made without any memory of the accurate words or phrases from the text. In a pure text-base, the reader applies previous knowledge to create a more perfect and consistent mental representation. The situation model is a structure that combines the text-base and the related features of the reader's knowledge. In order to create a text-base, some previous knowledge is required but this knowledge is a more general one that is necessary for decoding texts in general, while the previous knowledge in the

formation of a situation model is more specific regarding the content of the text.

Meanwhile, in relation to Content Literacy, they explained that Content literacy is the ability to read, understand, and learn from texts from a particular matter. There are three types of content literacy: general literacy abilities, content-specific literacy abilities, and previous knowledge of content. The general and the content-specific literacy abilities indicate some more general type of knowledge that does not hinge on the detailed content of a particular text. This knowledge is applied to make a text-base in the mental representation.

Previous knowledge of content is the knowledge that is related to the content of a particular text and is applied to make a situation model in the mental representation. For example, it is not obvious that mathematics makes a necessity for content-specific literacy abilities and the reading comprehension in mathematics hinges on more general literacy abilities and previous knowledge. It can be stated that the symbolic language in mathematics is the main cause for the need of content-specific literacy skills.

Furthermore, concerning with Cognitive Processes, they states that the application of syntactic and semantic rules together with the activation of more particular previous knowledge occurs automatically and unconsciously. Various cognitive processes are more or less conscious. Perception is defined as the highly automatic and unconscious processes. For instance, when we see a dog and directly know it as a dog; we are conscious of the outcome of the process but there aren't any active and conscious thought processes for this identification. Problem solving deals with active thinking when we want to remember the name of a person we see and know. Accordingly, when we read a text without having any difficulties in comprehending what we read, the process is related to perception than problem solving because the process of comprehending is

unconscious. This comprehension is located somewhere between perception and problem solving.⁶⁰

Reading comprehension is an interactive process between the writer and reader, with the expression and reception of meaning as the primary goal of both parties. A writer expresses his or her thoughts, ideas and feelings via the written word, and hopefully, this writing effectively expresses this intended message to a reader. The reader should actively think about what they are reading prior to, during, and after the act of reading.

According to Nunan, reading comprehension by definition refers to a process that involves actively constructing meaning among the parts of the text and personal experience.⁶¹ There is a “construction process” in comprehension because it involves all of the elements of the reading process working together as a text is read to create a representation of the text in the reader's mind. Similarly, Snow states that reading comprehension is the process of simultaneously extract and construct meaning through interaction and involvement with written language.⁶²

Thus, reading comprehension consists of three elements; the reader, the text, and the activity or purpose of reading. Furthermore, Nutall defines reading comprehension as activity done by a reader to achieve particular purposes such as particular piece of information, solving problem through reading, working to understand an idea or following a set of direction.⁶³ Constructing meaning from the text is the main objective of reading comprehension activity. McNeill adds that the things such as decoding ability, knowledge of the vocabulary

⁶⁰ Abbas Pourhosein Gilakjani and Narjes Banou Sabouri, “How Can Students Improve Their Reading Comprehension Skill,” *Journal of Studies in Education* 6, no. 2 (2016): 229–240.

⁶¹ David Nunan, *Language Teaching Methodology: A Textbook for Teachers* (Prentice Hall, 1991).

⁶² Catherine Snow, *Reading for Understanding: Toward an R\&D Program in Reading Comprehension* (Rand Corporation, 2002).

⁶³ Nuttall, *Teaching Reading Skills in a Foreign Language*.

presented, familiarity with the concept and cognitive development are factors which effect reading comprehension.⁶⁴

Reading difficulties become most apparent when the student is unable to grasp the meaning from a text passage. Reading comprehension may be affected by the difficulty of the text, the vocabulary words used in the text, and the student's familiarity with the subject matter, among other factors. A reader's understanding of reading will be affected by the comprehension strategies they are utilizing, their background knowledge and experiences with the topic of the passage being read, and a reader's interest in this topic. A teacher can provide students with a variety of reading materials, utilize a variety of reader response activities, and provide both the time to read as well as some motivational readiness activities.

B. Types of Reading Comprehension

Readers employ different types of comprehension in order to understand fully what they read. According to Burn, at al., comprehension covers literal and high-order comprehension. Reading for literal comprehension or acquiring information that is directly stated in a selection is important in and of it and is also a prerequisite for higher level comprehension. Higher-order reading comprehension includes interpretive, critical and creative comprehension.⁶⁵ To read between the lines is interpretative reading, to read for evaluation is critical reading and to read beyond the lines is creative reading. In this case, readers will apply the classification depending on their level of reading.

Meanwhile, Brown explained two kinds of reading, namely extensive reading and intensive reading. Intensive reading is text reading or passage reading. In this reading, the learner read the text to get knowledge or analysis. The goal of this reading is to read shorter

⁶⁴ John D McNeil, *Reading Comprehension: New Directions for Classroom Practice*. (Scott: Foresman and Company, 1984., 1984).

⁶⁵ Burns, Roe, and Ross, *Teaching Reading in Today's Elementary Schools*.

text. This reading is done to carry out to get specific information. Learner reads book to acquire knowledge is the kind of intensive reading. Furthermore, in intensive reading the reader tries to absorb all the information given by author. For instance, reading dosage instruction for medicine. On the other hand, in extensive reading, the reader deals with longer text as a whole, which requires the ability to understand the component parts and their contribution to the overall meaning. This reading activity aims to help the reader familiar with the words that frequently appear in the certain text. Brown assumes that extensive reading (free voluntary reading) is a weapon for students to gains in reading ability, spelling, vocabulary and writing. For example, reading a newspaper, novel, short story and an article.⁶⁶

C. Indicators of Reading Comprehension.

If readers can read the words but they do not understand what they are reading, they are not really reading. Below are indicators of reading comprehension.

1. Students are able to construct meaning from text.
 - a. Students are able to activate background knowledge before, during and after reading text.
 - b. Students are able to monitor their own understanding of text, identify what they do not understand and are able to use appropriate (fix-up) strategies to synthesize what they read.
 - c. Students are able to create visual and other sensory imagery from text during and after reading.
 - d. Students identify and interpret vocabulary critical to the meaning of the text. Students are able to generate questions to integrate information from text.
 - e. Students retell text orally and/or in written form.

⁶⁶ H. Douglas Brown, *Teaching by Principles: An Interactive Approach to Language Pedagogy*.

- f. Students summarize text orally and/or in written form
 - g. Students use graphic aids and illustrations.
2. Students are able to examine and extend the meaning of the text.
 - a. Students respond to text in oral discussion and written form.
 - b. Students make inferences from text.
 - c. Students are able to compare complex concepts of text.
 - d. Students can analyze the text structure and story elements.

From those indicators, it appears that the students should fulfill a wide variety of requirements for being able to read in reading comprehension activity. The teachers can employ those indicators as instruments to see and judge precisely the ability of the students in understanding what they read. The most important one is the teachers are able to interpret those indicators into the choice.

D. Levels of Reading Comprehension

Reading comprehension has different levels. Burns divides reading comprehension into literal reading, interpretative comprehension, Critical thinking and Creative thinking.

1. Literal Comprehension

Literal reading comprehension is lowest level of comprehension. The term literal comprehension refers to the ability to understand and to recall information that has been explicitly stated in a text. The text may be written and spoken. According to Smith and Robinson literal comprehension is getting the meaning of a text only on its surface. They state that there is no depth in this kind of reading. Some specific reading skill at the literal level of comprehension are identifying specific information or nothing details, when explicitly signal is given, finding the main idea and the content of the reading text. This level of reading comprehension will be the requirement for the the highest level of reading comprehension.

a. Identifying specific information.

This reading requires one to focus reader attention only on one or some particular information or detail which he need form of a text; the rest of the text may not be read anymore. That information may be a name, a date, a scientific term, or a place or just anything. The search for which motivates the person to read. In looking for detail, the reader must look for signals in the environment of the needed information or in the information itself.

b. Finding main idea

The main idea is the most important piece of information the authors wants you to know about the concept of the paragraph. Main idea is central thought around which the whole paragraph is organized. It is usually expressed in a topic sentence; identifies the subject matter. They state the main idea of the paragraph. Often the first sentence in the paragraph; sometimes at the end or middle. Not all sentences have topic sentences. Main idea is supported by details a well-written paragraph. g) When the main idea is not directly stated readers can determine it by discovering the topic to which all the stated details are related. Main idea of whole selection may be determined by examining the main idea of the individual paragraph and deciding what topic they are related.

2. Interpretive Comprehension

The second level is interpretive comprehension. At this level, students go beyond what is said and read for deeper meanings. They must be able to read critically and analyze carefully what they have read. Students need to be able to see relationships among ideas, for example how ideas go together and also see the implied meaning of this idea. At this point, Rubin further elaborates that some of reading skill in this level require readers to do things as follows:

- a) determining word meanings from context
- b) finding main idea

- c) reading between the lines or making inference.
- d) drawing conclusion
- e) making Generalization
- f) recognizing cause and effect reasoning
- g) recognizing analogies

3. Critical Reading

Critical reading includes both literal comprehension and interpretation, but also occurs after those two levels of comprehension, when reads critically; he evaluates what he has read.

4. Creative Reading

Creative reading occurs when a reader applies ideas to new situation and recombines the author's ideas with the other ideas to the new idea through the creative reading, the reader creates something new, for instance: an idea, the solution to the problem, a new of looking at something from the idea got from the text.

E. Strategies for Reading Comprehension

For most second language learners who are already literate in a previous language, reading comprehension is primarily a matter of developing appropriate, efficient comprehension strategies. Brown proposes ten strategies for reading comprehension that can be applied in the classroom, namely:

1. identify the purpose in reading
2. use graphic rules and patterns to aid in bottom-up decoding (especially for beginning level learners)
3. use efficient silent reading techniques for relatively rapid comprehension (for intermediate to advanced levels)
4. skim the text for main ideas
5. scan the text for specific information
6. use semantic mapping or clustering

7. guess when you aren't certain
8. analyze vocabulary
9. distinguish between literal and implied meaning
10. capitalize on discourse markers to process relationships.⁶⁷

The following are detail explanation of each of the strategies for reading comprehension above.

- (1) Identify the purpose in reading

Efficient reading consists of clearly identifying the purpose in reading something. By doing so, students know what they are looking for and can weed out potential distracting information. In short, students should know their purpose in reading something.

- (2) Use graphic rules and patterns to aid in bottom-up decoding (especially for beginning level learners).

At the beginning level of learning English, one of the difficulties students encounter in learning to read is making the correspondences between spoken and written English. In many cases, students have become acquainted with oral language and have some difficulties learning English spelling convention. They may need hints and explanations about certain English orthographic rules and peculiarities.

- (3) Use efficient silent reading techniques for relatively rapid comprehension (for intermediate to advanced levels).

When teaching beginning level of students, the particular strategy will not apply because they are still struggling with the control of a limited vocabulary and grammatical pattern. The intermediate-to-advanced level students need not be speed-readers, but they can increase efficiency by applying a few silent reading rules: they don't need to "pronounce" each word to themselves, try to visually perceive more than one word at a time, preferably phrases, and skip over a word that is not crucial

⁶⁷ Ibid.

for global understanding and try to infer its meaning from context.

(4) Skim the text for main ideas.

Perhaps the two most valuable reading strategies for students are skimming and scanning. Skimming consists of quickly running one's eyes across a whole text for its gist. Skimming gives readers, the advantage of being able to predict the purpose, the main topic, or message and possibly some of the developing or supporting ideas.

(5) Scan the text for specific information

The second in the most valuable category is scanning or quickly searching for some particular piece or pieces of information in a text. Scanning exercises may ask students to look for names or dates, to find a definition of a key concept, or to specific information without reading through the whole text. For academic English scanning is essential.

(6) Use semantic mapping or clustering

Readers can easily be overwhelmed by a long string of ideas or events. The strategy of semantic mapping, grouping ideas into meaningful clusters, helps the reader to provide some order to the chaos. Making such semantic maps can be done individually, but they make for a productive group work technique as students collectively induce order and hierarchy to a passage.

(7) Guess when you aren't certain

This is an extremely broad category. Students can use guessing to their advantage to guess the meaning of a word, a grammatical relationship, discourse relationship, and infer implied meaning, a cultural reference and content message.

(8) Analyze vocabulary

One way for learners to make guessing pay off when they don't immediately recognize a word is to analyze it in terms of what they know about it. The techniques that may be applied are to

look for prefixes that may give clues, to look for suffixes that may indicate what part of speech it is, to look for root that are familiar, to look for grammatical contexts that may signal information and to look at the semantic context (topic) for clues.

- (9) Distinguish between literal and implied meaning.

This requires the application of sophisticated top-down processing skill. The fact that not all language can be interpreted appropriately by attending to its literal, syntactic surface structure makes special demands on readers. Implied meaning usually has to be derived from processing pragmatic information. This kind of meaning is not easily distinguished from contextual meaning, but in some examples it can be clearly established that a distinction exists. This is the meaning that reflect the writer's feeling, attitudes and so on, and his attention that the reader should understand these.

- (10) Capitalize on discourse markers to process relationships

Many discourse markers in English signal relationship among ideas as expressed through phrases, clauses, and sentences. A clear comprehension of such markers can greatly enhance students reading efficiency. The markers are enumerative, additive, logical sequence, explicative, illustrative, and contrastive.

Another effective strategy for reading comprehension elaborated by Gilakjani and Sabouri by extracting a number of experts' opinion. They state that there a lot of effective strategies for reading comprehension. They are Activating and Using Background Knowledge, Generating and Asking Questions, Making Inferences, Predicting, Summarizing, Visualizing, and Comprehension Monitoring. Detail explanation of the strategies above are the followings.

- a. Activating and Using Background Knowledge

In this strategy, readers activate their background knowledge and apply it to aid them comprehend what they are reading. This knowledge consists of individuals' experiences with the world together with their concepts for how written text work, involving word recognition, print concepts, word meaning, and how the text is formed. Schema theory is very important in comprehension process. This theory is based on how people form and activate their previous knowledge. This theory explains that as persons learn about the world, they create a series of knowledge structures or schemas. These schemas develop and shift as the persons learn new information through experience and reading. For instance, a child's schema for dog can involve her or his comprehending of the family pet such as white, furry, and fun. When the child gets more experiences with a lot of dogs in different environments, the dog schema develops and can be improved. It can relate to other schema-kinds of dogs like colors of dogs; foods that dogs eat; places where they stay when the family is on holiday; and dangerous dogs. Cognitive scientists stated that successful readers permanently relate their prior knowledge to the new knowledge they face in texts. Good readers activate their schema when they start reading. The first schema impacts how readers comprehend and react to a text. Schemas are particularly significant to reading comprehension. When learners have knowledge of a text's organization, this can help them to understand better that text.

b. Generating and Asking Questions

In this strategy, readers ask themselves pertinent questions in reading the text. This strategy assists readers to combine information, recognize main ideas, and summarize information. Asking appropriate questions permits successful readers to concentrate on the most important information of a text. Creating relevant questions helps good readers to concentrate on difficulties with comprehension and to take the necessary actions to solve those problems.

c. Making Inferences

Readers assess or draw conclusions from information in a text. In this strategy, writers do not always provide full information about a topic, place, personality, or happening. Instead, they provide information that readers can use to read by making inferences that integrate information of the text with their previous knowledge. Through this process, readers can improve their skills to make meaning. Being able to make inferences is an important factor for readers' successful reading.

d. Prediction

In this strategy, readers are able to gain meaning from a text by making educated guesses. Successful readers apply forecasting to make their existing knowledge to new information from a text to obtain meaning from what they read. Before reading, readers may apply what they know about a writer to forecast what a text will be about. The title of a text can operate memories of texts with the same content, permitting them to guess the content of a new text. During reading, successful readers can make predictions about what will occur next, or what opinions the writer will offer to support a discussion. Readers try to assess these predictions ceaselessly and change any prediction that is not approved by the reading.

e. Summarizing

Readers combine information in a text to elaborate in their own words what the text is about. Summarizing is a significant strategy that allows readers to remember text rapidly. In this strategy, readers can be aware of text structure, of what is significant in a text, and of how opinions are related to each other. Effective summarizing of explanatory text includes things like condensing the steps in a scientific process, the steps of development of an art movement, or the episodes that result in certain important historical happenings. Effective summarizing of narrative text includes things such as connecting happenings in a story line or recognizing the elements that stimulate a character's activities and conduct.

f. Visualizing

Readers can make mental picture of a text to comprehend processes they face during reading. This skill shows that a reader perceives a text. Readers who form a mental image as they read are better able to remember what they have read than those who do not image. Visualizing is very important when it is used for narrative texts. When readers read narrative texts, they can easily understand what is happening by visualizing the place, personalities, or operations of a plan. It can also be used for the reading of expository texts. Readers visualizing steps in a process or stages in a happening or forming an image that help them to recall some abstract ideas or significant names.

g. Comprehension Monitoring

In this strategy, readers have the ability to know when they comprehend what they read, when they do not perceive, and to apply suitable strategies to make better their understanding. Successful readers know and check their thought processes as they read. Strategies that successful readers use to improve their understanding are called “fix-up” strategies. Particular repair strategies involve rereading, reading ahead, explaining the words by looking them up in a, or asking someone for assistance. Successful readers try to use different strategies to make meaning as they read. They do not use similar strategies; instead, they like to expand and practice those strategies that are beneficial to them. Moreover, they are very flexible in the application of their strategies, they change from strategy to strategy, and they apply various strategies with different types of texts. The important point here is that successful readers can make good decisions about which strategies to apply and when to use them. A lot of students can gain from explicit instruction that teaches them to apply particular strategies for understanding a text. The other point is that particular comprehension strategies can be

taught and learned and that their conscious use can help readers to ameliorate their comprehension.⁶⁸

F. Skills of Reading Comprehension

Reading every word of a text is not always necessary in the reading activity. Spending too much time on individual words can distract one's understanding of the text being read. In addition to the strategies, readers use to make sense out of point, successful readers also use reading skills.⁶⁹ Students need to be able to do a number of things with a reading text. So it is clear that skills of reading comprehension are set of skills which the reader has to be dealt with reading a text.

According to Alexander, skills of reading comprehension include:

1. finding the main ideas
2. remembering details
3. recognizing sequence
4. following direction
5. summarizing and organizing information
6. generalizing
7. predicting outcomes.⁷⁰

These skills of reading comprehension are very useful for the readers to make reading effective and efficient. Below are detail explanation of the points above.

(1) Finding the main ideas

Finding main ideas is a skill which attempts to get a global understanding of the text. Comprehending main ideas has been

⁶⁸ Pourhosein Gilakjani and Sabouri, "How Can Students Improve Their Reading Comprehension Skill."

⁶⁹ Jerry G Gebhard, *Teaching English as a Foreign or Second Language: A Teacher Self-Development and Methodology Guide* (Michigan: University of Michigan Press, 2000).

⁷⁰ J.E.Alexander, *Teaching Reading* (Scot, Foresman and Company: Boston, n.d.).

considered important to the comprehension process. Techniques to find the main ideas are various. These most often involve summarization or searching for key words and topic sentences.

(2) Remembering details

Remembering details is a skill which requires a reader to remember specific or detailed information in the text. The specific or detailed information may refer to the name of a person, date of a day and a place. Reading for details can be developed through some of the questioning procedures.

(3) Recognizing sequence

Recognizing sequence is the ability to note the order or a sequence of events to grasp the cause-effect relationship involved and to anticipate the rest of the story in the text.

(4) Following direction

Following directions is a skill to find out how to do things through printed direction. These printed directions can help a reader to know how to do something. In printed directions, we need to be able to read carefully and accurately and to follow a series of directions precisely in correct order

(5) Summarizing and organizing information

Summarizing and organizing information is a skill of a reader to sum up and organize the information in the text. It can be stated by recognizing what the author wants to say, think out the order, sequence, relative importance and the interrelatedness of the specific ideas which is intended to convey, and plans of the exposition accordingly.

(6) Generalizing

It is the skill of a reader to generalize information in the text. The ability to generalize is usually related to higher-level comprehension.

(7) Predicting outcomes

Predicting outcomes is a skill of a reader to predict the text to follow or what the end of the text will be. One of the most common techniques is to stop children before they finish reading a story and have them suggest how the story or text could end.

All these skills play an important role in order to assist a reader is supposed to be able to determine the particular skills to be used in comprehending a written text on the basis of appropriate context.

G. Teaching Comprehension Strategies

Teachers should make decisions about how to teach their students to read in order to gain understanding or get meaning from the text they are reading. Teachers must realize that strategies or methods are needed to help the students improve their comprehension.

According to Brown, reading comprehension is primarily a matter of developing appropriate, efficient comprehension strategies. Furthermore, he states that teachers can encourage students to become active participants in the classroom community by tailoring their instructional strategies and methods to the needs of their classes and individual in those classes.⁷¹

There are many reading strategies teachers can apply to help their students improve their comprehension for the fact that the students' understanding of the text being read are frequently affected by the comprehension strategies they are using. According to Tierney, et al., comprehension strategies are tactics or procedures which effective readers utilize to interact with written text, and to understand this writing on a literal, inferential, critical and creative

⁷¹ H. Douglas Brown, *Teaching by Principles: An Interactive Approach to Language Pedagogy*.

level. Effective readers employ such strategies automatically prior to reading, as they read and once they have finished reading.⁷²

In this writing, there are four kinds of strategies for teaching comprehension that will be elaborated namely, visualizing, inferring, making connection and questioning, Teachers can use these strategies to assist their students in the process of their comprehension. While at some point, students need to be able to utilize these strategies effectively on his or her own.

1. Visualizing

Visualizing is creating pictures in our minds. When students visualize, they create their own picture in their minds. Teachers can use pictures on the book to help the students build up their image on the topic they read. When we read, we create an image in our mind. We read and create the image with what we know or have experienced. Teachers can help the students create their images through lessons that evoke the thought processes.

2. Inferring

Inferring is being able to reach opinion from the facts while reading the text. To help the students find inferences, the teachers can use pictures on the book. The pictures give clues to help the students gain meaning. In addition, the students can use his or her imagination and prediction to find inferences on the lesson they read. Teachers need to have their students try to make conclusions about the reading and make reasonable predications.

3. Making Connections

Students make connections between books they read to their own lives. Teachers can help their students connect things from books to real world happenings. By doing this, it enhances the students' understanding. Teachers can develop their instruction

⁷² Robert J Tierney and others, *Reading Strategies and Practices. A Compendium* (Boston: Allyn and Bacon, Inc., 1985).

around certain components that help their students find the connections and help them comprehend. The genre can range from fiction, nonfiction, poetry, etc. When the student experiences these and become more familiar with each type of genre, they learn special characteristics and conventions of the genre. The student also can learn about how authors write about certain themes, topics, or issues. The student can usually find a topic they can enjoy from an author. Also the style the author writes in can influence an appreciation from the reader.

At the beginning, making connections can be difficult. The student learns from modeling by the teacher and peers. The student learns that making connections help with understanding. They learn that prior knowledge helps them make the important connections.

4. Questioning

Questions are the key to understanding. Students need to feel that their questions are important. We as teachers need to model by asking and answering questions. When students ask questions they have a desire to learn for understanding. This leads to comprehension. There are several ways a teacher can use questioning in their lessons. One is the teacher can share their own questions they may have when they are reading. By doing this, it can stimulate students to ask questions about what they read.

Another strategy for questioning is the use of a book of questions. When the students are reading and they have a question about something, the students can make a list of questions. When the class is discussing the reading, the class can help answer the students' questions. Teachers can focus the questions on something that make the students see what they know about a topic. Teachers can make a different type of question. The question deals with something that the students may not know the answer. The question may require thinking by the teacher and the class.

H. Assessment of Reading Comprehension

Assessment as one of the important aspects of teaching and learning should be carried out by teachers, including teachers who teach reading comprehension. By assessment, it is hoped that the process and quality of instruction conducted can be described or reflected. In addition, by assessment, teachers can evaluate their own performance in carrying out instruction and provide information about the results or achievements of their students' learning which can then be used as a basis for making important decisions about the teaching learning activities carried out, whether the teaching and learning is successful or otherwise fails at all. In other words, the assessment can show whether the teaching and learning activities carried out meet what the teacher expects from their students or not.

Basically, assessment is related to how to measure students progress and learning outcomes, both during and after participating in learning activities. According to Nitko and Brookhart, assessment is a process of collecting information from students to make certain decisions.⁷³ This means that the assessment will produce information and feedback. Meanwhile, Brown, suggests that assessment is an ongoing process that involves a wider domain so that in conducting assessments teachers must consider various aspects such as participation, attendance, motivation, portfolio, assignments and others.⁷⁴ The same opinion was expressed by Huba & Freed in Ates and Buyukkarci which stated that as a continuous activity, assessment is carried out to observe and improve student learning activities, lessons at school and the environment in which the learning takes

⁷³ Anthony J Nitko and Susan M Brookhart, "Education Assessment of Students," *New Jearsey: Merrill Prentice Hall* (2007).

⁷⁴ H. Douglas Brown, *Teaching by Principles: An Interactive Approach to Language Pedagogy*.

place.⁷⁵ More specifically, Cheng in Kirkgoz et al. asserts that assessment is a process of collecting information from students to help make decisions about the progress and development of students' language.⁷⁶ Thus, assessment is an important part that cannot be separated from learning activities and teachers are expected not to stop conducting assessments, either programmatically or incidentally.

In relation to reading comprehension assessment, Habib states that assessment of reading comprehension can be conducted in the form of tests, projects, and daily classroom activities. Indeed, the construction of simple and well-organized tests which entail various tasks and activities is important for this type of assessment in order to address students' texts comprehension. In order to assess reading comprehension, teachers should use several methods and no single technique can truly measure students' reading skills. A reading comprehension test may subsume activities such as: gap filling, short questions, multiple choice questions, true or false questions, and yes-no questions. The main goal of reading comprehension tests is to measure reading mastery without stressing grammar or spelling. However, in assessing reading, failure to take errors in language use into consideration may lead to the perception that spelling, grammar, and punctuation are not essential to language learning. Therefore, reading comprehension assessment should target not only students' comprehension of a text but also the factors that facilitate or impede this comprehension. In order to actually check students' comprehension of texts, various types of questions should be used. In fact, approaches to the evaluation of reading comprehension have tried to introduce interactive activities and tasks. The use of

⁷⁵ Hüseyin ATE\cS and Ka\ugan BÜYÜKKARCI, "International Journal of Languages' Education and Teaching Volume 7, Issue 2, June 2019, p. 294-318" (n.d.).

⁷⁶ Yasemin Kirkgoz, Muzaffer Pinar Babanoglu, and Reyhan Ağcam, "Turkish EFL Teachers' Perceptions and Practices of Foreign Language Assessment in Primary Education.," *Journal of Education and e-Learning Research* 4, no. 4 (2017): 163–170.

questions is an integral part of these activities and well-designed questions would help learners better interact with the text to build up meaning. Indeed, a combination of comprehension activities helps learners respond to various types of comprehension.⁷⁷

Furthermore, Sally and Katie in Habib state there are numerous methods and forms of reading comprehension tasks that can be used in assessing students' comprehension and stimulating their understanding of a text. These techniques may take formal or informal forms. The tasks are the following.

a. Yes-No Questions

These are questions that should be answered with either yes or no. However, teachers are recommended to follow up these questions by other types of questions to make sure that students have understood the text as Yes/No questions can be answered correctly by chance.

b. True or False questions

This is another type of a reading test that is familiar to most learners. It consists of a text accompanied by a series of statements. Learners need to decide and mention whether the given statements are true or false according to the text. This kind of reading comprehension questions provides learners with a set of sentences or statements. For answering these questions, learners are required to read the text and discover the true and the false statements without giving answers in a complex written response. They are good activities for memory of literal details in the text but they are limited in assessing specific comprehension skills such as making inferences and meanings. More importantly, teachers should not rely exclusively on them because, like Yes/No questions, learners can give right answers by chance without knowing why these answers are correct. True or False

⁷⁷ HABIB Madani and others, "Assessment of Reading Comprehension," *Revista Românească pentru Educație Multidimensională* 8, no. 1 (2016): 125–147.

questions need to be carefully designed because the false answers should target the potential misunderstandings of a text. Besides, the false answers that sound obviously incorrect do not help teachers assess learners' comprehension because learners do not need to understand the text to recognize them as incorrect.

c. Matching

This type is likely to be less familiar to learners, but increasingly common. They are used by many assessors. Some of reading comprehension tests designers may include more than one matching task in their tests. For doing a matching task, learners need to choose from a list of prompts. These prompts may be statements, headings, or question completion. For instance, learners can be asked to match a description to the appropriate paragraph, or to match words and phrases to their meanings.

d. WH Questions

Wh questions are questions that begin with Wh such as: “where”, “why”, “who”, “when”, and “how”. These questions are useful in providing learners with literal understanding of a text and help them recognize information in the text and make evaluations and personal predictions.

e. Open -Ended Questions

These questions are used in standardised assessments. They are useful in assessing the component skills of comprehension such as the ability of learners to make inferences from the text. In fact, learners are asked different questions for the reason of testing their memory and their comprehension of the text. However, it is important to mention that this form of assessment may have some weaknesses because learners have to formulate verbal or written responses which may underestimate their comprehension because of their language deficits.

f. Multiple-Choice Questions

This type of the reading task is the most familiar to learners. It is composed of a text which can be of any type accompanied by one

or more multiple choice items. These choices may be in the form of statements, a question with answers, or incomplete statements with a choice of phrases or words. Generally, there are three or four options and only one of them is the right one. It is important to have statements corresponding to specific paragraphs or sections of the text, but there may be statements that assess comprehension of the whole text. Developing a good multiple-choice question needs a careful consideration. In fact, a question with four choices works best for learners with low proficiency in the target language, and one of the four choices should sound the right and the desired answer. Literal comprehension can be checked more effectively by the use of multiple-choice questions. Besides, they can also be used for prediction and evaluation. However, these questions need to be followed by other activities to make learners explain their choices. Generally, this type of questions may have one correct answer when it targets the literal comprehension. Actually, a multiple-choice format with “wh” question is easier than no-choice “wh” question because it pushes learners to check the text to know if any of the choices are discussed.

g. Gapped Texts

This kind of reading comprehension test includes texts or diagrams from which single words, phrases, sentences, or paragraphs are deleted. These filling the gaps tasks can also be used in testing grammar and vocabulary. In some tasks, learners have to decide what should fill in the gap, while in some others, they are given a series of alternatives for choice. Where words, sentences, or paragraphs are removed, there is an item among the given alternatives that is odd to the text. Gapped texts offer a task that can be used in testing or assessing learners’ reading skills. It can be applied to all types of texts and can be included in lower-level exams and for learners with low-level performance.⁷⁸

⁷⁸ Ibid.

Meanwhile, in scoring the students' reading comprehension, there are some aspects of measuring reading comprehension, namely:

a. Different Sound

While the students are asked to read the text, the teacher will assess them by hearing their pronunciation or the sound that the students may say

b. Paraphrase Recognition

Paraphrase recognition means that the students are able to develop the main idea by using their own words. The teacher will assess them by looking at the way of they develop the main idea and also coherence between the main idea with supporting idea.

c. Information Transfer

The teachers assess the students reading comprehension not only through their pronunciation, but also how they transfer the information to others (listener).

d. Finding the Stated Information

This study focuses on literal comprehension, so the aspects to be concluded in text are paraphrase recognition and finding the states information. It means that the teacher does not assess students through their findings on the printed page.

CHAPTER IV TEACHING ENGLISH IN INDONESIAN ISLAMIC HIGHER EDUCATION

A. Short Overview

English courses in Indonesian universities are generally grouped into Personality Development Courses (MPK) which are mandatory for students. The purpose of this course is to equip students with active communication skills in English, namely listening, speaking, reading and writing skills. As a compulsory subject, English is delivered in the form of a general subject where the delivery method is in the form of lectures, discussions, group work and direct language practice or role play. Teaching English (language teaching) based on the needs and interests of students is generally grouped into two, namely general English and special English (English for Specific Purposes or ESP). General English learns about grammar (fundamentals of grammar), expressions and phonetics. ESP studies English based on the occupational profession or specific needs of students such as science and technology, socio-culture, economics, agriculture, education and health.

B. Objectives of Reading Instruction

In Islamic higher education, foreign languages are one of the courses that students must take. The foreign language is English. The field of teaching English with a specific purpose or better known as the English for Specific Purpose (ESP) is a relatively new field of teaching English by adjusting scientific majors in tertiary institutions. By teaching English in Islamic tertiary institutions, it is hoped that students will be able to study Islamic scholarship in foreign languages, especially English and be able to follow the development of world globalization which requires someone to be able to master a foreign language.

Nowadays, English has been taught in Indonesia's Islamic University. It is not only as a general subject from all various major in the university but also specifically as a special field of language education faculty. For those, the challenge in teaching English, especially in Islamic University which is first focused on Islamic subject and substance, is getting higher and complicated. Moreover, when the Islamic University want to apply the integrated curriculum, science and religious education, in every field and major.

English constitutes one of the compulsory subjects offered, not on at both junior and senior high schools, but also at the higher man institution, i.e. at university level in Indonesia. In the higher education institution curriculum, it falls under the subject group of what usually named Mata Kuliah Umum (MKU). Islamic higher education as part of the Indonesian higher education system, therefore, offers the English subject to be taken by all of the students from different faculties and departments. One of the train objectives in teaching English at the Islamic higher educations, especially at the undergraduate program, run either by the government or both private independent foundations and private foundations under certain religious organizations in Indonesia, such as the State Islamic University (UIN), the State Institute for Islamic Studies IAIN), and the State College for Islamic Studies (STAIN) as well the Islamic faculties in the secular or general universities, is primarily in order their students, mostly with multilingual background, are able to read the textbooks and articles on Islam written in English by both Muslims and non-Muslims. Since the textbooks and articles to handle deal widely with different subjects in the field of Islamic studies, the English to be taught can then be included as part of English for special purposes or English for specific purposes (ESP). ESP is

defined by Hutchinson and Water as an approach to language teaching which aims to meet the needs of particular learners.⁷⁹

The purpose of learning English in the context of ESP (English for Specific Purpose) in Islamic tertiary institutions is that students are able to use English both in writing and orally in understanding the reading in English texts specifically for majors in each faculty. The learning objectives are in accordance with English teaching and learning which is divided into English 1, English 2, English 3, and English 4. In particular, the purpose of learning English 1 is so that students can understand basic English Grammar and basic reading skills. (teaching English in general), the purpose of which refers to teaching ESP is that students are expected to have knowledge of sentence structure in English, techniques for reading comprehension of texts written in English, and be able to understand the meaning of vocabulary in the context of Islamic studies. (teaching English for special purposes). Students are able to understand English Grammar and books and journals related to science and technology. (ESP). Students are expected to have competitive and comparative advantages according to competency-based national and international quality, especially in building and developing English language skills and skills both spoken and written which include: listening, speaking, reading, and writing.

C. Materials for Reading Instruction

Teaching material plays an important role in achieving a teaching goal. In accommodating with those objectives, the teaching of English uses genre to familiarize the students with various texts for communication in English. Therefore, the students are offered to learn more about genre. Genre of English language teaching that has to be learned in Indonesian context at the level of the Islamic junior

⁷⁹ Tom Huchinson and Alan Waters, *English for Specific Purposes: A Learning-Centered Approach*, NY: Cambridge (Cambridge: Cambridge University Press, 1991).

high school is composed by descriptive, procedure, narrative, recount and report texts. In the second year, the students have to learn only descriptive, narrative and recount text.⁸⁰ The three texts are explained as follows.

The English teaching in higher education has been determined as a compulsory subject.⁸¹ However, it just weighs two credits. It is not enough to make graduates proficient in English. Although some universities have added more credits for English, the government needs to be more serious by making clear regulation or law related to English teaching at higher education so that we will have graduates that can compete in the global world. So far, learning English courses at UIN Mataram contain general English materials. Material is taken from an English book or text book published from abroad. Topics or themes in textbooks are mostly about things that are grammar in nature.

D. Teaching and Learning Reading Approaches

Communicative language teaching (CLT) is an approach that regards language as a system for the expression of meaning; primary function-interaction and communication. It has become the accepted orthodoxy of TEFL over the past.⁸² General courses refer to communicative goals, communicative practice or communicative methodology. It means that the activity in this approach is the activity that can engage learners in communication. The activity of communication involves sharing processes such as information sharing, negotiation of meaning, and interaction. Thus, the role of learners is as negotiators, giving as well as taking. While the teacher has the role as a facilitator of the communication process, manager,

⁸⁰ Gedung D Lt and Mandikdasmen Jl R S Fatmawati, “Badan Standar Nasional Pendidikan” (2006).

⁸¹ Tim Paradigma Pendidikan BSNP, “Paradigma Pendidikan Nasional Abad XXI,” *Jakarta: Badan Standar Nasional Pendidikan* (2010).

⁸² Alan Cunningsworth, *Choosing Your Coursebook* (Macmillan, 1995).

counselor, need analyst, participants' tasks and texts. The task is an activity that requires learners to use language, with emphasis on meaning, to attain the objective. That definition emphasizes that meaning is primary in the task. It means that in a task there are some communication problems to solve; there is some sort of relationship to comparable real-world activities. Besides task completion has some priority; and the assessment of the task is in terms of outcome. TBLL or CLT can facilitate the teachers in teaching four English language skills including listening, reading, writing and speaking as the language competence. Listening and reading include receptive skills in which there is a process to save a lot of inputs in brain. In contrast, writing and speaking include productive skills that produce outputs. In addition, teachers are expected to encourage the students to master language components including grammar, vocabulary and pronunciation. Further informations are explained below:

In learning activities, lecturers in conveying the learning process use approaches, methods, and techniques. With the existence of approaches, methods and techniques of learning activities will be colorful/varied and these activities can also be carried out well. According to Subana and Sunarti, the term approach is often associated with methods and techniques. All these terms are three related aspects. The approach is used to refer to the syllabus design (syllabus design) and the approach is philosophical or axiomic, while the method is a way of carrying out learning.⁸³ Another case with techniques that contain understanding of the various methods and tools used by lecturers in the classroom.

Thus, technique is the effort, effort, method used by the lecturer in achieving direct goals in the implementation of teaching. When referring to the above understanding, of course the lecturer understands how to use and apply learning methods in accordance with the teaching material used. The teaching material used will be

⁸³ Sunarti Subana and Others, "Strategi Belajar Mengajar Bahasa Indonesia," *Bandung: Pustaka Setia* (2009).

complete and understandable by students if the lecturer can apply learning methods appropriately and effectively. Based on the results of observations in English learning activities in class, it can be seen that most of the lecturers have used various student-centered learning methods (student center). This can be seen from the use of role playing learning methods, active learning, discussion, presentation, and others. In addition to using student-centered learning methods (student center), learning English in almost all Islamic universities mostly uses teacher-centered learning methods (lecturers). This can be seen by the dominance of lecturers using the lecture method in delivering lecture material. Apart from that, it was seen that the lecturers were still using the assignment, training, audiolingual methods, and so on.

E. Teaching Reading at UIN Mataram

In general, reading comprehension instruction is directed to help the students develop their reading skills so that they can get information from any texts they read. Students are expected to read a lot in order to absorb information for their study. As a result, the teacher has to teach good reading strategies and provide good reading materials.

According to the curriculum of UIN Mataram, English is one of the foreign languages offered to students in order that they can communicate in English. The total credit for English subject at UIN Mataram is 10. As a prerequisite subject, students learn English in various level, namely from English Matriculation 1 to English 2. This is intended to provide the students larger opportunities to learn English.⁸⁴

The teaching of English at UIN Mataram has a main purpose to give the English skill to the students, specifically in order that they can understand and comprehend English textbooks. Beside that, by

⁸⁴ *Kurikulum UIN Mataram.*

learning English, the students of UIN Mataram are expected to be able to communicate widely with English speakers.

One way to meet the objectives is by teaching the students reading comprehension besides teaching them grammar or structure and other skills under the consideration that reading enables the students to learn the text structure and vocabulary. The role of the teachers is very important too, to facilitate the students in their learning and help them achieve what they need. In other words, students' reading competencies should be the main concerns of the teacher. In order to provide the students with these competencies, the teachers should develop good materials for the teaching of reading at UIN Mataram.

F. Assessment of Reading

In general, assessment and evaluation must be done by every EFL teacher. Most teachers conduct a test or examination to measure the students' achievement in EFL teaching and learning. The tests can be either diagnostic or prognostic. The words 'test' and 'examination' have a considerable amount of overlap of meaning. They may measure someone's present achievement or delineate his present weaknesses, or they may claim to measure potential. Normally, teachers conduct tests to make assessment and evaluation. The test may be either subjective or objective. In the subjective test, the scoring is impressionistic, not necessarily reliable, dependent to some extent on the marker's whim or judgment. In the objective test, there is a list of items each with only one correct answer, and the marker's task is simply mechanical to total the number of 'rights' and 'wrongs'. An example of a subjective test is the marking of an English essay. An example of an objective test is the multiple choice type of test with the instruction to the students to tick the correct answer. Tests might measure linguistic competence, or they might measure particular skills. Tests can be written or oral. In constructing a test or examination, we need to check the validity in the sense that

it measures what it is intended to measure. It is possible for an examination to be reliable but not valid. Reliable means that different examiners award the same marks to the same paper. In general, examinations are more ominous for students than tests. Students might have semester examinations but weekly tests. Examinations sound more serious than tests.

Assessment is one of the important parts of teaching area in Islamic higher education. It can be expected that the overall quality of the teaching and learning in higher education will be reflected on the assessment.⁸⁵ By assessment, lecturers in Islamic higher education can evaluate their performance in the classroom, as well as the assessment can describe the student's outcomes. However, the results of assessment are sometime ignored by the lecturers. The results are only put in their assessment expertise through in service courses. Consequently, the assessment is not beneficial any more to achieve their objectives.⁸⁶ Nitko and Brookhart have defined assessment as a process to get information from students for a particular educational decision. The definition points out that the assessment should provide information about the performance of students in order to produce feedback for them.⁸⁷ Nevertheless, in many cases the information that have been attained is unreliable and invalid. Consequently, the decision that has been resulted from the invalid information is not useful to the institution, lecturers, and students.

Assessment can be divided into formative and summative, in terms of objective of assessment. The formative assessment is used to encourage learning. This kind of assessment is designed to help students in their learning process. The formative assessment always provides feedback to the learner or student. The feedback is used to

⁸⁵ Richard James, Craig McInnis, and Marcia Devlin, *Assessing Learning in Australian Universities: Ideas, Strategies and Resources for Quality in Student Assessment* (Australian, Universities Teaching Committee, 2002).

⁸⁶ James A Athanasou and Iasonas Lamprianou, *A Teacher's Guide to Assessment* (Social Science Press, 2002).

⁸⁷ Nitko and Brookhart, "Education Assessment of Students."

underline areas for further study and to improve performance. There are several focuses of feedback, such as to tell students how they can improve their performance, to identify students' strengths and weaknesses, to predict success, and above all to provide feedback to lecturers, students, as well as a profile of what a student has learned. If formative assessment focuses on learning process, the summative assessment focuses for grading. This kind of assessment is used for external purposes and does not normally afford extensive feedback to the student. As for grading, the summative test is deliberately to pass or fail a student, as well as grade or rank a student.

Various types of assessment have been used in Islamic universities, such as multiple choice, essay assessment, portfolio, peer assessment, and journal assessment. The multiple-choice is a form of examination where examinees are asked to choose one of choices from a list. The multiple-choice can be considered as a simple assessment, in terms of the taxonomy of educational objectives, because the assessment only apply in knowledge and comprehension as the lowest level of cognitive.⁸⁸ Therefore, this assessment uses a word such as identify, define, or describe to ask student. Using the multiple-choice form in assessment can be beneficial for lecturers, department, and students. For lecturers or educators this kind of assessment can be easily marked. Furthermore, the scoring of this assessment may be more accurate and objective because students cannot produce their personal perception and misunderstanding to the question. The benefit of the multiple choice assessment for department is that the result may be easily used for comparing it to other programs, because the result may determine the strengths and weaknesses of the program.⁸⁹ For students, the multiple choice form can be set up at different cognitive levels. For instance, a question may apply in regard to get the ability of student for revealing facts.

⁸⁸ Ibid.

⁸⁹ John Carneson, Georges Delpierre, and Ken Masters, "Designing and Managing Multiple Choice Questions," *Retrieved March 30 (1996): 2008.*

However, on the other hand, this kind of assessment may not be beneficial. As mentioned above, the multiple choice assessment produces the lowest level of cognitive effort. Consequently, this assessment is built on lower-order thinking and it is hard to attain real achievement information of students. The disadvantage of the multiple choice assessment to program is that the assessment may be inadequate to cover the program's learning objectives and can not capture all the learning that has taken place, especially in the affective domain. For students, this assessment can not encourage them to think critically because the assessment only provides them with answer choices.

The second type of assessment is essay assessment. Essay assessment is defined as an assessment by which the examinee will be asked to give responses to the test. Stalnaker in Coffman asserts that Most of these responses consist of several sentences. The common characteristic of essay assessment is that student may get more freedom to respond to the questions, because there is no single answer will be listed as a correct answer.⁹⁰ By doing an essay assessment, students can develop their arguments, reflect, evaluate, assess and judge, as well as demonstrate their knowledge and understanding.⁹¹ It can be predicted that essay assignment produces high level of cognitive domain, referring to the Bloom's taxonomy, namely knowledge, comprehension, application, analysis, synthesis, and evaluation.

There are several reasons that make educators prefer to use the essay assessment, such as an essay examination is more convenient and easier to prepare. However, with this assessment, it is quite difficult to get consistent grades for students. Different assessors may produce different scores for one student. As a consequence, this kind

⁹⁰ William E Coffman, "On the Reliability of Ratings of Essay Examinations in English," *Research in the Teaching of English* 5, no. 1 (1971): 24–36.

⁹¹ Lee Dunn, Chris Morgan, and Sharon Parry, "Seeking Quality in Criterion Referenced Assessment" (2002).

of assessment cannot design procedures for analyzing. Another advantage of essay assessment is that it can develop student's ability to write, because the students will be asked to reflect their opinion and idea in writing form. Nevertheless, the writing ability may influence the objectivities of the result of the assessment. Assessors may have bias in their scoring, because they are interested in the ability of student's writing rather than the content of the student's answer.

Portfolio assessment is another type assessment that have been used in higher education. It can be defined as a collection of students' works reflecting their skills, achievements, learning and their competencies.⁹² In simple word, portfolio contains student's records to assess their progress. Portfolio assessment may take many different forms of assessment, and many different purposes. One of them is that the students should write about their own topics, with the assistance from the lecturers to select, and to support them in working with their topics of interest. The main reason to produce portfolios is because educators believe that students understand their capability and achievements rather than others. By doing portfolio assessment teachers become providers and facilitators to arise awareness of student about their competencies.⁹³ One advantages of using portfolios is that the lecturers will get more information about student's progress. By using portfolios, lecturers can encourage the students to decide their own styles of learning. As a result, the students feel that they are important parts of the assessment processes. Portfolios may help students for continuous learning process, because they will demonstrate performance, evaluation, and revision. On the other hand, portfolio has some disadvantages, such

⁹² Terence Love and Trudi Cooper, "Designing Online Information Systems for Portfolio-Based Assessment: Design Criteria and Heuristics," *Journal of Information Technology Education: Research* 3, no. 1 (2004): 65–81.

⁹³ Helen Woodward, "Reflective Journals and Portfolios: Learning through Assessment," *Assessment & Evaluation in Higher Education* 23, no. 4 (1998): 415–423.

as the difficulty to get reliable scoring in this assessment. Another disadvantage is that portfolio needs more time and consume more energy from the lecturers to do it. Another type of assessment that has been used in higher education is peer assessment. It is defined as an arrangement for peers to consider the level, value, worth, quality, of successfulness of the products or outcomes of learning of others of similar status. Peer assessment has been extensively used in formative assessment, even though it can be also employed in summative assessment.

There are some advantages of using peer assessment, such as to encourage student to be active in their classes. Peer assessment may also improve the critical thinking of students by analyzing others' work. Besides, it will give students a wider range of feedbacks, and peer assessment can help the lecturers to reduce the marking load on. However, peer assessment also has some disadvantages, namely students may not have adequate ability to evaluate each other, assessment by peers may not be done seriously, as a consequence, the marking is not objective any more. Peer assessment may also give student misinformation about each other, without guidance from the lecturer.

Another type of assessment that can be used in Islamic higher education is journal assessment. Journal assessment is a means of collecting information from the students on the effectiveness of a subject.⁹⁴ This kind of assessment is a part of authentic assessment or performance assessment that allow student to demonstrate application of knowledge. There are three forms of journal assessment, namely logs, diaries, and reflective journals. A log is a record to collect facts or performance relating to what happen. Diaries are reflecting on students' feelings. Reflective journals can consist both of them. The advantage of using journal assessment is

⁹⁴ Olivier Luminet et al., "Relation between Alexithymia and the Five-Factor Model of Personality: A Facet-Level Analysis," *Journal of personality assessment* 73, no. 3 (1999): 345–358.

that department can get rich information, particularly about complex situation and environment of study. Another advantage of journal assessment is that the data from journal can provide student's perception in teaching and learning, can help to improve both lecturers' and students' performance. Journal also helps the evaluator to monitor whether course outcomes are being met, because there are many data that can be got from journal assessment. The disadvantage of journal assessment is that it is hard to get validity of assessment. The data may be distorted. Students may produce their writing in order to influence readers rather than to demonstrate their real perceptions. Like other qualitative methods, issue of validity becomes the main concern. Journal assessment also is not beneficial due to time consuming. There is large amount of data provided by journal. As a consequence, journal assessment needs more time to perform.

CHAPTER V INSTRUCTIONAL DEVELOPMENT

A. Concept of Instrucional Development

In general, instructional development is a process of determining and creating certain situations and conditions that cause students to interact in such a way that there is a change in their behavior. According to Welker, Urbach and Buck, instructional development is a systematic way to identify, develop and evaluate a set of learning materials and strategies with the aim of achieving certain goals.⁹⁵ Beside that, Atwi Suparman states that what is meant by instructional development is a systematic process in identifying problems, developing instructional materials and strategies, and evaluating their effectiveness and efficiency in achieving instructional goals. In another language arrangement it is said that what is meant by instructional development is a systematic process in achieving instructional objectives effectively and efficiently through identifying problems, developing instructional strategies and materials, and evaluating these strategies and instructional materials to determine what should be revised.⁹⁶

The two definitions above contain the same meaning, namely, a) the goal or end result of instructional development is a set of instructional materials and strategies that are effective and efficient in achieving instructional goals. This result is also called the instructional system, b) The instructional development process begins with identifying problems, continues with developing strategies and instructional materials, then ends with evaluating their effectiveness and efficiency. The evaluation process here includes revision activities.

⁹⁵ Paul A Twelker and others, "The Systematic Development of Instruction: An Overview and Basic Guide to the Literature." (1972).

⁹⁶ Suparman Atwi, "Desain Instruksional Modern," *Jakarta: Penerbit Erlangga* (2012).

Another concep of instructional development comes from Seal and Ritchie in Gustafson and Branch. They explained that instructional development is an organized procedure that include the steps of analyzing, designing, developing, implementing, and evaluating instruction. Therefore, according instructional development consists of at least four major activities, they are:

1. Analysis of the setting and learners needs.
2. Design of a set of spesification for an effective, efficient dand relevant learner environment.
3. Development of all learner and management materials.
4. Evaluation of the result of the development both formatively and summatively.⁹⁷

Instructional development is always based on experience, peer observation and controlled experimentation. There are two development processes; The first is an empirical approach that uses the theoretical foundations of teaching materials based on the developer's experience. The second approach is the model approach. In the preparation of the teaching design there are steps in a system: the way to achieve it is chosen in certain ways, certain conditions and certain changes. The results of the trial provide certain information that can be used as an assessment material regarding the level of difficulty of a program. This instructional development consists of a set of activities including development planning and evaluation of the instructional system that is being developed so that it has been revised several times and can be satisfactory for development. Instructional development is a management technique in finding solutions to instructional problems or at least optimizing the use of existing learning resources to improve education. Learning development has a broader meaning because it includes learning design. Learning development is a systematic approach in the design of production, evaluation and utilization of a complete learning

⁹⁷ Kent L Gustafson, *Survey of Instructional Development Models* (ERIC Clearinghouse on Information \& Technology, 1991).

system that includes all the right system components with a management pattern for using them.

B. Models of Instructional Development

1. The Nature of Model

In general, the model is a framework that can be used as a guide in carrying out an activity. Models usually summarize complex or complex information into simpler and easier to understand ones. The model can be seen as an effort and to concretize a theory as well as an analogy and representation of the variables contained in the theory. Some experts looked at a model as a mental picture that helps us understand something we cannot see or experience directly..

Model is defined as something such as an object, plan, or set of rules that is used to show what something else is like or how it works.⁹⁸ According to Robins, a model is an abstraction of reality; a simplified representation of some real-world phenomenon.⁹⁹ The purpose of this definition, the model is a representation of several phenomena that exist in the real world. The definition of a model was also expressed by Miarso that a model is a representation of a process in graphic and or narrative form, by showing its main elements and structure.¹⁰⁰ In this case, it is possible to interpret the narrative model in graphic form, or vice versa. According to Brown et al., a model is a shadow or reflection of the real thing. A model may describe commonalities among a number of similar items; illustrate a process; and a representation of the real things.¹⁰¹ A model is a plan or a pattern that can be used to design instruction and to

⁹⁸ “<https://Dictionary.Cambridge.Org>.”

⁹⁹ S.P Robins, *Organizational Behavior: Concepts, Controversies, Applications* (New York: Prentice Hall, Inc., 1996).

¹⁰⁰ Y. H. Miarso, “Survei Model Pengembangan Instruksionalemakalah Yang Disampaikan Sebagai Bahan Ajar Kuliah Mahasiswa S3 Program Studi Teknologi Pendidikan Pascasarjana UNJ” (2011).

¹⁰¹ Abbie H Brown and Timothy D Green, *The Essentials of Instructional Design: Connecting Fundamental Principles with Process and Practice* (Routledge, 2019).

shape instructional materials. Models have descriptive, prescriptive and or explanatory elements in different degree while designing instruction.

From these definitions, it can be concluded that the model is a process of thinking and the components contained therein, which are represented in graphic and or narrative form. Another opinion is that models are that describe the teaching-learning process. A model is a visual aid or picture which highlights the main ideas and variables in a process or a system. The models presented in this paper include words or diagrams intended to give an understanding of the variables associated with school learning.

Specifically, in the context of educational research and development, models are usually presented in the form of development procedures according to the development model chosen to outline the steps to be followed to produce a product. With the selected model, a number of inputs or inputs can be obtained to improve the resulting learning products. In learning system design, the model usually describes the steps or procedures that need to be taken to create effective, efficient, and interesting learning activities. So a model in learning development is a systematic process in the design, construction, utilization, management and evaluation of learning systems.

2. The Importance of Instructional Development Models

Gustafson and Branch states that instructional development models serve as conceptual and communication tool for analyzing, designing, creating, evaluating guided learning ranging from broad educational environment to narrow training application. The greater the compatability between a model of instructional development and its contextual, theoretical, phloshophical and fenommenominal orogins, the greater potential for success in constructing episodes of guded learning. Instructional development modeling is one way to take into account the multiple backround of learners, the multiple

interaction that may occur during learning, the variety of context in which learning is situated, and the necessity to guide, manage and communicate the instructional development process.¹⁰²

Instructional planning activities can be developed with various models and manipulated learning. Of the various existing learning design models, there is no one that is the most appropriate learning design model. Therefore, in determining the design model for developing a learning program depends on the designer's (teacher, lecturer, or trainer) consideration of the model to be used or selected. Experts have introduced a wide variety of models in developing materials using the R&D approach. The models are principally the same in goal, but different in procedures, depending on such factors as educational system, condition of learners and teachers, learning situation, etc.

Generally speaking, there are many instructional design models which are developing in the world of education today, for example SAFE (System Approach For Education), Michigan State University Instructional Systems Development Model, Project MINERVA Instructional System Design, Teaching Research System, Banathy Instructional Development System, Dick & Carey model, Kemp model, Three Phase Design Model, The 4CID Model, ARCS Model, and many other instructional models. Its development also varies according to the conditions and objectives of the instructional design it is intended for, which is clear that each model is intended to produce an instructional system that is effective and efficient in facilitating the achievement of instructional goals. Basically, the instructional models offered have procedures that are almost the same as one another, or even combine various existing models to be applied to the learning environment we face.

The procedure or process adopted by instructional system developers can include two ways, namely with an empirical approach and by following or creating a model (paradigm approach). With an

¹⁰² Gustafson, *Survey of Instructional Development Models*.

empirical approach, this process is carried out without systematically using theoretical foundations. Here, packages or teaching materials are arranged based on the developer's experience, students are asked to study and then the results are observed. If the results are not as expected, the teaching material is revised and the work of compiling the teaching package (material) is repeated. This approach has several drawbacks, some of which are (a) every developer must start from scratch to find or find all the steps and basics needed to develop a teaching material and (b) repeatedly making new teaching materials (packages). This means repeated trials, and this means less efficiency.

Meanwhile, according to paradigm approach, the expected learning outcomes can be classified according to certain types. For each type of specific objective (objective), certain ways can be chosen to achieve it, certain conditions for observing student response can be created, and changes if necessary can be made. In the preparation of instructional design, steps are carried out systematically, so that empirical testing of a program can encourage information about the effectiveness of a program, which is also possible to test the model. Atwi Suparman suggests a comparison analysis of several instructional models consisting of three stages, namely: the definition stage, the analysis and system development stage, and the evaluation stage.¹⁰³ It is further argued that the differences between one model and another include: the target or level of use (institution or subject), the use of terms at each stage, the number of stages or steps, the completeness of the concepts and principles used.

3. Review of of Instructional Development Models

The review of instructional development models presented in this part is intended to introduce and promote some effective teaching and learning activities in the classroom. And of course, there is no single model that is universally accepted as perfect fit for

¹⁰³ Atwi, "Desain Instruksional Modern."

facilitating classroom instruction. In fact, there are many instructional models available for the teacher to adopt as guide to achieving the desired learning outcome. This review does not include all the model but only presenting some popular models of instructional development taken from Joshua's article and his friends which entitled "A Review of Instructional Models for Effective Teacher Education and Technology Integration." According to Joshua et al, there are at least fifteen popular instructional development models which can aid teachers or instructors to effectively select and structure teaching strategies, methods, skills, and student activities for a particular instructional purpose. However, not all of the model will be discussed here, only nine models selected in accordance to the need and purpose of the writer. The models are Assure Model, ABCD Format, The Addie Model, Hannafin and Peck Model, Knirk and Gustafson Model, Icare Model, Samr Model, Tpack Model, and The Dick and Carey Model. The detail explanation of each of the models are the followings.¹⁰⁴

a) ASSURE Model

The ASSURE model is a six-step instructional systems design model developed by Smaldino et al. (2008) which was intended to help teachers utilize technology and media in the regular classroom.

A- ANALYZE LEARNERS: Who are your students? At this level, a trainer understands who his learners are, obtains certain information about them, for example, their prior knowledge, learning styles, and academic abilities and then consume this knowledge into lesson planned.

S- STATE STANDARDS & OBJECTIVES: What are your objectives and lesson outcomes? Develop a syllabus to teach which will be used in your classroom alongside with specific objectives that

¹⁰⁴ Chukuwumeka Emeka Joshua et al., "A Review of Instructional Models for Effective Teacher Education and Technology Integration," *Sumerianz Journal of Education. Linguistics and Literature* 3, no. 6 (2020): 86–95.

will be the main focus of single lessons which will lead to a specific outcome.

S- SELECT MEDIA AND MATERIALS: What methods are to be used in delivering this lesson? Before you choose the media and materials to help you deliver instruction, the intended instruction delivery method should first of all be chosen. For example, you might decide to use a collaborative or individualistic approach for the assessments. After which you can select the media or material that best back up or enhances the method of instruction you have chosen such as PowerPoint lesson presentations and can help the student best master the lesson.

U- UTILIZE MEDIA AND MATERIALS: How you get the selected media & material implement? In this step, the chosen media is being implemented but care should be taken by providing alternative lesson solution in case of technology failure. What do I require to transfer my PowerPoint slides? What if the USB drive didn't work?

R- REQUIRE LEARNER PARTICIPATION: What should you do to motivate learners' participation? Mediums that encourages learners' participation (Thinking, Solving, Creating, Developing, and Analyzing) such as assessments, classwork's etc. will aid feedback. To apply a teaching method beyond lecturing, it becomes a necessity to integrate technology into the lesson planned.

E - EVALUATE AND REVISE: How did the lesson meet its objectives? How effective were the material and media used help student participation? What more improvement can be made? Evaluations are done both on the instructors and the learner's part. Learners' may be given the opportunity to relate and apply the experiences they encountered during the lesson.

b) ABCD Format

ABCD model is a format used in writing objectives. In ABCD model lesson objectives much be; Visible and quantifiable, Clear, Results-focused, determined by quantitative and qualitative standards,

Talk about successful learning in behavioural terms etc. Objective writing is an important subject to take into consideration because a clear objective will make it easier for the teacher to see and meet the goals of the instruction. Following the ABCD objective format makes lesson preparation an easy ride for success in achieving stipulated milestones. ABCD Objective format consists of four components:

A- Audience: These are the group of the focus of which the lesson is prepared for. To begin with, in objective preparation, the description of the intended learner or individuals is necessary. Who is the target of the outcome? Example: “The Lecturers attending this seminar...”

B- Behaviour: The description of the learner’s ability should be determined and should be observable and measurable. What should the audience be able to know, do, or value? Example: “... should be able to relate their classroom experiences...”

C- Condition: This refers to the situation the behaviour will take place. What equipment will be utilized? Example: ...under a video constructed environment on Friday...

D- Degree: This provides the acceptable Standard of measurement or criteria for success. Example: ... within 15 mins.

c) The ADDIE Model

Addie model is a five-phase standard process used by instructional designers and training developers for effective training and performance. It was initially developed by Florida State University. The 5 phases represents a dynamic, flexible standard for building effective training and performance support tools. ADDIE stands for Analysis, Design, Development, Implementation, and Evaluation which represent the five steps or phases applied to develop instructional materials.

A-Analysis: a systematic exploration of the way things are and the way things should be the difference is the performance gap.

D- Design: if the analysis identifies performance gap, the design phase will outline the performance objectives.

D- Develop: Using information in the analysis and design phase, the performance solution is created.

I- Implement: This step includes delivery of the performance solution.

E- Evaluation: Measurement of how well the performance solution achieved the objectives.

d) Hannafin and Peck Model

The Hannafin Peck is a three-phase process model designed in 1987. In the first phase, a needs evaluation is carried out, followed by the second – design phase. In the third phase, instruction is established and applied. The phases in this model involve a process of evaluation and revision. Requirements analysis phase: during this phase, the Designer or developer has to make an assessment, particularly on the characteristics of the target group to ensure that the design process has guidance and direction that can be followed.

Design phase: Application design process begins with determining the objectives to be achieved by the user after using the application.

Development and implementation phases: The phase of development refers to the process of material production. In this phase, all the elements that were designed in the previous phase are translated into more practical either with the help of programming languages and authoring.

Evaluation Phase: at this phase, the overall view of the shape, structure, teaching approaches, learning theories, media and technology types that will be involved is a matter to be investigated.

e) Knirk and Gustafson Model

The Knirk and Gustafson's design method and model was designed in 1986, with three stage process. They are problem determination, design and development. This is a prescriptive stage model for instructional designers. The problem determination stage: includes identification of the problem, the definition of the pedagogical goals and identification of what the learners can do (knowledge, skills, learning styles, affect, etc.)

The design stage: includes developing objectives and specifying strategies.

The development stage: includes the development of materials, testing and revision. In revision, materials that are used should be evaluated based on student behaviours, the criteria level, and aiming towards the instructional goals. It is a simple design that can be used in both designing unit plans and single lesson plan but its evaluation and development do not occur until later process.

f) ICARE Model

The ICARE model is an instructive framework for instructional design practice. This is done by implementing numerous steps of instructions which are particularly useful sections of an online course. Below are the basic components:

I- Introduction: This phase consists of the introduction to the unit of instruction and includes context, Aims, Fundamentals, Obligatory study time, Equipment required, Essential reading materials.

C- Connect: This phase familiarizes the students with necessary facts, theories, principles, and processes.

A- Application: This phase provides tasks and practices that allow students to apply the knowledge gained previously from the Connect phase.

R-Reflect: This phase encourages learners to take some periods in order to reproduce what they've learned as they move from the Connect and Apply phase.

E-Extend: The extend phase gives room for chances to individualize learning experiences.

g) SAMR Model

This is one of the popular models of technology integration. It was originally proposed by Peuntedura (2006). Its inherent assumption is that technology can fundamentally redefine the nature of the educational activity. The model proposed four possible levels of technology integration in the classroom, namely:

1. Substitution
2. Augmentation
3. Modification
4. Redefinition

Substitution occurs when either the teacher or the student use technology to facilitate or access learning with no functional change. Augmentation extends teacher and student use of technology by offering a functional change afforded by technology selected. Modification involves the use of technology which allows for significant task redesign and Redefinition involves a situation where technology is used to allow for the creation of new tasks. The first two stages were described by educationists as the enhancement levels. Furthermore, the remaining two stages educationists' described as transformation levels where modification and redefining of learning activities is done through the use of technology.

h) TPACK Model

TPACK which is known as Technological Pedagogical Content Knowledge is a framework developed to help describe the kind of knowledge that educators need in order to teach effectively while integrating technology. This conceptual model developed by Koehler and Mishra (2005) was based on Shulman's Pedagogical Content Knowledge model. The framework contains seven constructs arising from the intersection of the three major knowledge dimensions namely; Technology Knowledge (T or TK), Pedagogical Knowledge (P or PK) and Content Knowledge (C or CK). See Figure below; The major knowledge dimensions are represented with three overlapping distinct circles to form a Venn system, each circle representing the teachers' knowledge. At the connection of these components lies the understanding of teaching subject matter with appropriate pedagogical methods and technologies. The intersection of the three major dimensions brought about formation of three more knowledge constructs namely, Technology Pedagogical

Knowledge (TPK) which arises from the intersection between TK and PK, while Technological Content Knowledge (TCK) arises from the intersection of TK and CK and Pedagogical Content Knowledge (PCK) at the intersection of PK and CK. The interconnection of all the knowledge constructs reveals the last knowledge constructs called Technological Pedagogical Content Knowledge (TPACK). Thus, TPACK includes knowledge of how to make concepts understandable by using technology, knowledge of how to use technology with pedagogical knowledge in order to meet students' needs, knowledge of the difficulties in learning concepts and how to eliminate these difficulties by using technology, knowledge of students' epistemological beliefs and background knowledge and how to increase their epistemological beliefs level by using technology. Furthermore, TPACK framework can be useful for planning lesson contents, methods and approaches for transferring content knowledge and respective technologies associated with content and pedagogy. It can also be used for assessment of pre-service teachers' knowledge and appraisal of inservice teachers' knowledge while serving as a professional development and technology integration framework for educational stakeholders such as the National Universities Commission and other school administrators.

i) Dick and Carey's Model

Dick and Carey's model is a routine system including components – nine of which are basic steps inside an iterative cycle and one which is a culminating evaluation of the effectiveness of the instruction, designed in 1996. The details about the Dick and Carey model of instructional development will be discussed in separate section as this model was used as the basis for developing reading instructional material in this study.

C. The Dick and Carey Model of Instructional Design.

However, the development of materials in this study adopted a model from Dick and Carey which is based on the research on the process of instruction and followed by elaborating steps, starting with analysis and ending with judgment and revision of the instructional design system using certain procedures. The Dick and Carey instructional model was developed in 1978. The model focused on a systematic approach to designing instruction. It has an iterative process that starts by identifying instructional goals and ends with summative evaluation. Later on, Dick, Carey and Carey elaborated the Dick and Carey model for instructional design that became widely known and utilized sharing common attributes in addition to recent trends in education including constructivism.¹⁰⁵ The Dick & Carey Model is based on research into the learning process and describes a series of steps, beginning with analysis and ending with assessment and revision of a procedural instructional design system. It is intended for the design of instruction rather than of curriculum. This model consists of ten steps, namely the followings.

1. Identify an instructional goal
The purpose is to identify what the learners are expected to learning at the end of the lesson.
2. Conduct an instructional analysis
the purpose is to define a step-by-step of what will be done by the learners while performing the goal and also determine the skills acquired.
3. Analyze learners and contexts
The purpose is to identify the enabling skills the learners already have before the instruction.
4. Write performance objectives
The purpose is to be able to interpret the needs and goals into achievable objectives. What the learners are able to do with the

¹⁰⁵ Dick, Carey, and Carey, *The Systematic Design of Instruction*. 6th.

skills, the statements of the skills to be learned, the conditions, and the criteria.

5. Develop assessment instruments

The purpose is to create a criteria-referenced assessment that is dependent on the performance objectives.

6. develop an instructional strategy

The purpose is to outline how instructional activities connects to the accomplishment of the objectives by developing strategies in pre-instructional activities.

7. Develop and select instructional materials

The purpose is to select printed or other instructional media which are meant to deliver the events and produce the lesson,

8. Design and conduct the formative evaluation

The purpose is to provide data for revision and improvement of instructional materials.

9. Revise instruction

To use the data from the formative evaluation to examine the validity of the instructional analysis, student and context analysis, presentation objectives, evaluation instruments, instructional approaches, and instruction.

10. Conduct summative evaluation

The purpose is to know the level of efficiency the system has and the first classroom iterations with the focus being on the outcome.

The nine basic steps represent the general procedures that are employed in the process of designing instruction. Detail explanation of the whole steps are the following.

1. Identify an Instructional Goal

The first step in the model is to determine what it is that you want learners to be able to do when they have completed your instruction. The instructional goal may be derived from a list of goals, from a needs assessment, from practical experience with

learning difficulties of students, from the analysis of people who are doing a job, or from some other requirement for new instruction.

2. Conduct an Instructional Analysis

After you have identified the instructional goal, you will determine step-by-step what people are doing when they perform that goal. The final step in the instructional analysis process is to determine what skills, knowledge, and attitudes, known as entry behaviors, are required of learners to be able to begin the instruction. A diagram will be produced that depicts the relationships among all of the skills that have been identified.

3. Analyze Learners and Context

In addition to analyzing the instructional goal, there is a parallel analysis of the learners, the context in which they will learn the skills, and the context in which they will use them. Learners' current skills, preferences, and attitudes are determined along with the characteristics of the instructional setting and the setting in which the skills will eventually be used. This crucial information shapes a number of the succeeding steps in the model, especially the instructional strategy.

4. Write Performance Objectives

Based on the instructional analysis and the statement of entry behaviors, you will write specific statements of what the learners will be able to do when they complete the instruction. These statements, which are derived from the skills identified in the instructional analysis, will identify the skills to be learned, the conditions under which the skills must be performed, and the criteria for successful performance.

5. Develop Assessment Instruments

Based on the objectives you have written, develop assessments that are parallel to and measure the learners' ability to perform what you described in the objectives. Major emphasis is placed on relating the kind of behavior described in the objectives to what the assessment requires.

6. Develop an Instructional Strategy

Based on information from the five preceding steps, identify the strategy that you will use in your instruction to achieve the terminal objective. The strategy will include sections on pre-instructional activities, presentation of information, practice and feedback, testing, and follow-through activities. The strategy will be based on current theories of learning and results of learning research, the characteristics of the medium that will be used to deliver the instruction, content to be taught, and the characteristics of the learners who will receive the instruction. These features are used to develop or select materials or to develop a strategy for interactive classroom instruction.

7. Develop and select Instructional Materials

In this step you will use your instructional strategy to produce the instruction. This typically includes a learner's manual, instructional materials, and tests. (When we use the term instructional materials we are including all forms of instruction such as instructor's guides, student modules, overhead transparencies, videotapes, computer-based multimedia formats, and web pages for distance learning. We intend the term materials to have this broad connotation.) The decision to develop original materials will depend on the type of learning to be taught, the availability of existing relevant materials, and developmental resources available to you. Criteria for selecting from among existing materials are provided.

8. Design and Conduct the Formative Evaluation

Following the completion of a draft of the instruction, a series of evaluations is conducted to collect data that are used to identify how to improve the instruction. The three types of formative evaluation are referred to as one-to-one evaluation, small-group evaluation, and field evaluation. Each type of evaluation provides the designer with a different type of information that can be used to improve the instruction. Similar techniques can be applied to

the formative evaluation of existing materials or classroom instruction.

9. Revise Instruction

The final step (and the first step in a repeat cycle) is revising the instruction. Data from the formative evaluation are summarized and interpreted to attempt to identify difficulties experienced by learners in achieving the objectives and relate these difficulties to specific deficiencies in the instruction. The line in the figure on pages 2 and 3 labeled "Revise Instruction" indicates that the data from a formative evaluation are not simply used to revise the instruction itself, but are used to reexamine the validity of the instructional analysis and the assumptions about the entry behaviors and characteristics of learners. It is necessary to reexamine statements of performance objectives and test items in light of collected data. The instructional strategy is reviewed and finally all this is incorporated into revisions of the instruction to make it a more effective instructional tool.

10. Conduct Summative Evaluation.

Although summative evaluation is the culminating evaluation of the effectiveness of instruction, it generally is not a part of the design process. It is an evaluation of the absolute and/ or relative value or worth of the instruction and occurs only after the instruction has been formatively evaluated and sufficiently revised to meet the standards of the designer. Since the summative evaluation usually does not involve the designer of the instruction but instead involves an independent evaluator, this component is not considered an integral part of the instructional design process per se.

To sum up, the Dick and Carey model for designing instruction can be seen in Figure 3.1 below.

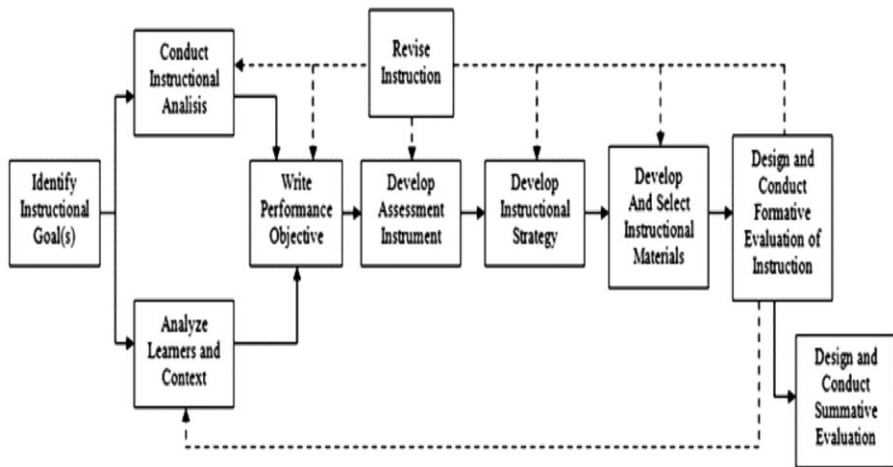

Figure 3.1 The Dick and Carey Systems Approach Model for Designing Instruction

However, it is also important to note here that the development of reading comprehension materials in this study did not completely follow the model as described in Figure 3.1. The model was adapted according to needs of the students. The adaptation of the model of Dick and Carey for developing materials covers a number of steps, namely (a) need analysis, (b) conduct an instructional analysis, (c) Analyze Learners and Contexts, (d) developing instructional materials, (e) expert judgment, (f) revision of the instructional materials, (g) try-out of the instructional materials, and (h) revision of the instructional materials. Detail explanation of the whole steps of the adapted or modified model are the followings.

a) Needs Analysis

In an ideal situation, the material developed should reflect the students' needs to study English. Different types of students have different needs and what they are taught should be restricted to what they need. Need analysis is a process of gathering information about the learners' need. It Generally describes learners, performance context, and tools that will be available in the context. Analyze students' needs aims to find out what do they expect to learn and what skill that need to develop to get the

achievement. The result of needs analysis becomes the basis for designing and developing instructional materials.

b) Conduct an Instructional Analysis

Once instructional goals are established, an instructional analysis can be developed. An instructional analysis is a set of procedures that help identify the skills and knowledge that should be included in instruction. It is important to identify which domain each instructional goal is linked to. The domain can be cognitive, affective, psychomotor, knowledge, comprehension, etc.¹⁰⁶

c) Identify Learners and Contexts

When determining the learners and the context in which the learning will take place, it is important to refer to the target population. When considering the target population, it is important to go beyond the context of the learner. When designing curriculum, the designer should consider the following about the target population: Skills prior to instruction Prior knowledge of the topic area Attitudes toward content and potential delivery Academic motivation Education and ability levels Learning preferences Group characteristics.¹⁰⁷

d) Developing Instructional Materials

The instructional materials contain the content. This can be either written information or facilitated by an instructor that the student will use to achieve the objectives. This may include any materials that are being incorporated into a lesson. Examples of this may include student workbooks, activity guides, problem scenarios, resource lists, textbooks, or computer simulations. When selecting

¹⁰⁶ Tyler D'Angelo, J C Bunch, and Andrew Thoron, "Instructional Design Using the Dick & Carey Systems Approach," *EDIS* 2018, no. 2 (2018).

¹⁰⁷ Ibid.

and developing instructional materials, it is imperative to align the materials to the objectives that have been set before.¹⁰⁸

e) Expert Judgment

Expert validation is the validation of the materials done by experts. According to Esseff, expert validation is a process of evaluating and revision of the developed material. In this case, experts are invited to evaluate the instructional material whether it is appropriate or not, practical or not, or effective or not.¹⁰⁹

f) Revision of the Instructional Materials

The results of experts validation were used to revise the instructional materials developed. This is the step in which revision is made based on the experts' input, comments and suggestion.

g) Try-out of the Instructional Materials

After the the developed material was revised based on the evaluation from the expets, the next step to do is to implement the developed material in a real teaching and learning situation. In this step, the researcher conducted a try out toward the instructional material developed to get feedback whether the the material was practical and effective or not. There were twenty students of UIN Mataram involved in the small group try out process and sixty students of UIN Mataram involved in the field try out process to evaluate the instructional materials developed.

h) Revision of the Instructional Materials.

Some revision was made based on the results of small group and field try out. At last, the results of this evaluation and revision were used for determining the validity, practicability, and effectiveness of the instructional materials and to develop a final product.

¹⁰⁸ Ibid.

¹⁰⁹ P.J. Esseff, *Developing Instructional Material* (Columbia: ESF Press, 1980).

To sum up, the the adapted or modified model are the is presented in Figure 3.2. below.

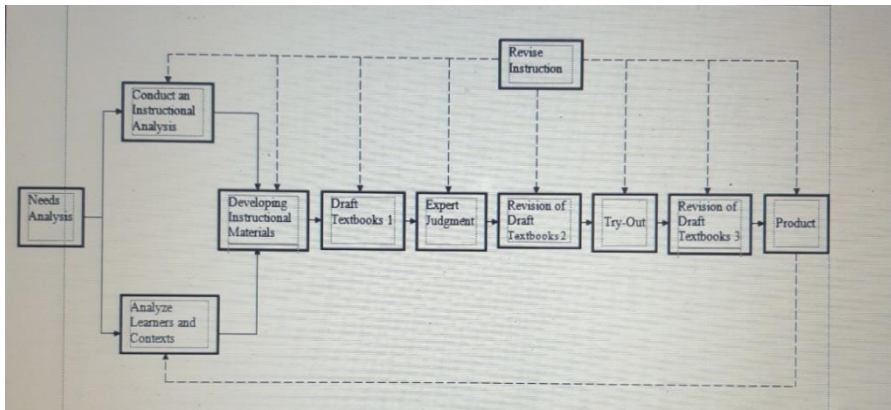

Figure 3.2 The Adaptation of the Dick and Carey Model for Developing Materials

CHAPTER VI MATERIAL DEVELOPMENT

A. Definition of Material Development

Learning material is one component of the learning system that plays an important role in helping students achieve competency standards and basic competencies. Learning material is a learning resource that contains messages in the form of concepts, principles, definitions, content clusters or contexts, data or facts, processes, values, abilities and skills. The material developed by the teacher should refer to the curriculum or be contained in the syllabus whose delivery is tailored to the needs and environment of students.

Materials may refer to any sources or information which can be used to write a book. They can come from literature, songs, newspapers, magazines, non-fiction books, radio and television programmers and from films. Tomlinson and Masuhara states that the term material in language teaching and learning refers to everything used to help teaching language learners.¹¹⁰ The use of material should take suitability into consideration in this case learners, teachers, and situation. Besides, it should meet some criteria before it is used. In the situation like the one which exist at Economics department, UIN Mataram, where there is no suitability between the materials and the students' need, improvement is needed.

Furthermore, development is an activity carried out to bring a design into physical form. The purpose of development is carried out to produce something that is expected to achieve learning objectives. Seels and Richey revealed that development is a process of translating or describing design specifications into physical form. Development can be interpreted as activities that are deliberate, systematic, aim at, formulate, improve, develop, produce, test the effectiveness of products, models, methods or strategies or ways, certain procedures

¹¹⁰ Brian Tomlinson and Hitomi Masuhara, *Developing Language Course Materials*Materials: RELC Portfolio Series 11. (Singapore: SEAMEO Regional Language Center, 2004).

that are superior, new, effective, efficient and meaningful.¹¹¹ According to Tomlinson and Masuhara, material development is everything made by people (the writers, the teachers, or the learners) to give and utilize information and provide experience of the using language, which is designed to promote language learning.¹¹² Borg and Gall states that materials development has its root in the strategy for developing educational product of proven effectiveness which is called educational research and development or sometimes it is contracted into R&D.¹¹³ He further states that R&D is a process used to develop and validate educational products. In relation to developing the materials, the process consists of some stages to be followed. The stages are: need assessment, reference study, material development, validation, and try-out.¹¹⁴

Material development is basically dealing with selection, adaptation, and creation of teaching materials. Practically, it focused on evaluation, adaptation of published materials and creation or development of teaching materials by teacher in line with the existing syllabus. So far, material development consists of the selection or evaluation of teaching material on the basis of a set of criteria or principles, the process of adapting teaching materials based on a set of criteria or principles the creation of teaching materials based on a set of principles, theories, and the syllabus developed by teachers.

According to Tomlinson, material developers might write textbooks, tell stories, bring advertisements into the classroom, express an opinion, provide samples of language use or read a poem aloud.¹¹⁵ Whatever they do to provide input, they do so ideally in

¹¹¹ Seels and Richey, *Instructional Technology: The Definition and Domains of the Field*.

¹¹² Huchinson and Waters, *English for Specific Purposes: A Learning-Centered Approach*.

¹¹³ Gall, Borg, and Gall, *Educational Research: An Introduction*.

¹¹⁴ Huchinson and Waters, *English for Specific Purposes: A Learning-Centered Approach*.

¹¹⁵ Brian Tomlinson, "Principles and Procedures for Self-Access Materials," *Reading* (2011).

principle ways related to what they know about how languages can be effectively learnt. We should focus on three vital questions, namely what should be provided for the learners? how it should be provided? and what can be done with it to promote language learning?

B. The Importance of Materials Development

The success of learning as a whole really depends on the success of the teacher in designing learning materials. Learning material is essentially an inseparable part of the syllabus, namely planning, predicting and projecting what will be done during the learning activity. The success of instruction is often determined by the availability of materials. According to Nunan, materials are an important element within the curriculum, and are often the most tangible and visible aspect of it. While the syllabus defines the goal and the objectives, the linguistic and experiential content, instructional materials can put flesh on the bones of these specifications.¹¹⁶ Furthermore, Richard and Rodger, suggest that instructional materials can provide detailed specification of content, even the absence of a syllabus. They give guidance to teachers on both the intensity of coverage and the amount of attention demanded by particular content or pedagogical tasks.¹¹⁷ Another role of teaching materials especially textbooks are as a source for presenting materials (spoken and written); a source of activities for practice and communicative interaction; a source of reference for learners on grammar, vocabulary, pronunciation, and so on, a source for stimulation and ideas for classroom activities; as a syllabus where they reflect learning objectives that have already been determined; and as a support for less experienced teachers who have yet to gain in confidence.

¹¹⁶ David Nunan, "Principles for Designing Language Teaching Materials.," *Guidelines: A periodical for classroom language teachers* 10, no. 2 (1988): 1–24.

¹¹⁷ Jack C Richards and Theodore S Rodgers, *Approaches and Methods in Language Teaching* (Cambridge university press, 2014).

In order to be able to develop the material which can improve the existing condition, there is a need to consider some functions of the material. There are some functions of the material according to Hutchinson and Waters, namely providing a stimulus to learning, helping organize the teaching and learning process, embodying a view of the nature of language and learning and providing model of correct and appropriate language use.¹¹⁸

Concerning the functions of the material, the material that will be developed should have the characteristics such as: the topic chosen should be familiar to student and not too difficult to them to understand, the task should be designed with the purpose of encouraging the student to use the English knowledge and skill they have learnt in each unit and in terms of format the material should be presented in a series of activities that can provide a coherent framework for integration of the various aspects of learning.

In relation to the development of reading materials, it should consider the students' need and background knowledge. Robinson states that the materials should fulfill the students' need because those materials will motivate the students to learn better and faster, whilst those materials relevant to the background knowledge of the students will help them achieve it.¹¹⁹ Beside the students' need and background knowledge, the reading materials also should suit the level of the students and offer a variety of exercises.¹²⁰ In addition, Tomlinson and Masuhara state that materials should be developed in ways which provide flexibility of use as well as coherence of

¹¹⁸ Hutchinson and Waters, *English for Specific Purposes: A Learning-Centered Approach*.

¹¹⁹ K.G. Robinson, *Curriculum Evaluation for Life Long Education* (Oxford: Pergamon Press, 1978).

¹²⁰ H. Ellington, *Producing Teaching Materials: A Handbook for Teachers And Trainers* (London: Kogan Page Ltd., 1985).

connection.¹²¹ Furthermore, Nunan states that the reading materials should be graded from easy to more difficult materials.¹²² Effective materials in language teaching are shaped by consideration some factors including the teachers, learners and contextual variables. Whatever materials used by teachers, they generally serve as the basis for much language input that the learners obtain and the language practice that occur in the classroom. Generally, teachers tend to use all guidance provided by a textbook. However, it is a fact that a textbook does not always meet the variety conditions in a language class. They often rely on that they are capable of writing worthy materials themselves. Nevertheless, all teachers are materials developers when they are involved in corresponding materials to the learners' needs. Here, some guides to help teachers to develop materials in order to make successful selections and adaptations, and as a basis for developing their materials.

C. Principles of Materials Development

In compiling and developing teaching materials in learning, it is necessary to pay attention to the principles of developing teaching materials, among others are:

1. starting from easy to understand difficult, from concrete to understanding abstract.
2. repetitions will strengthen understanding.
3. positive feedback will provide reinforcement of students' understanding.
4. High motivation to learn is one of the determining factors for successful learning.

Based on these principles, it is hoped that it can produce quality and efficient teaching language and in the end can help students achieve the learning objectives that have been designed beforehand.

¹²¹ Tomlinson and Masuhara, *Developing Language Course Materials*: *MATERIALS: RELC Portfolio Series 11*.

¹²² Nunan, "Principles for Designing Language Teaching Materials."

According to Tomlinson in Rochmawati, the basic principles in developing materials for the language teaching are the followings.

1. Materials should accept impacts.
2. Materials should help learners to feel at ease.
3. Materials should help learners to develop confidence.
4. What is being taught should be perceived by learners as relevant and useful.
5. Materials should require and facilitate learner's self-investment.
6. Learners must be ready to acquire the point being taught.
7. Materials should provide the learners with opportunities to use the target language to achieve communicative purposes.
8. Materials should take into account that the positive effects of interaction are usually delayed
9. Materials should take into account that learners have different learning styles
10. Materials should take into account that learners differ in effective attitudes.
11. Materials should permit a silent period at the beginning interaction
12. Materials should not rely too much on controlled practice.
13. Materials should provide opportunities for outcome feedback.¹²³

Furthermore, considering the needs as it is written previously, the writer decided to use the principles of materials design by David Nunan. He states that there are some appropriate principles in developing ESP materials some of which are the followings.

1. Materials should be clearly linked to the curriculum they serve. The reading texts should be about communication, and the topics of the texts students must have should be relevant to their study, such as the types and definition of communication etc.
2. Materials should be authentic in terms of text and task. Nunan says that texts and tasks are authentic if they were designed for purposes other than language teaching. An example of an

¹²³ P Rochmawati, *English Curriculum and Material Development*, 2017.

authentic text is one taken from a magazine and an authentic task is one that people do on their jobs.

3. Materials should stimulate interaction. Student-student interaction enhances language learning. For example, when they have to do peer correction, they will have greater opportunity to use language. Being critical to other's work, they will be aware of their own language. Since their works are corrected by their peers, they will have less stressful environment in using English.
4. Materials should allow learners to focus on formal aspects of language. When students write their comments, teachers and peers will correct their grammars and students will learn from the teacher's and the peers' input. This also explains the assignments of picking up readings from newspapers and magazines.
5. Materials should encourage learners to develop learning skills and skills in learning. Materials should make students able to develop further their skill in learning new things and develop their own basic knowledge to make further progress, both in the area of communication and in the language.
6. Materials should encourage learners to apply their developing language skills to the world beyond the classroom. As students have to write, give oral comments and discuss texts both from magazines and newspapers or other kind of readings, it is expected that they will be accustomed to writing, speaking, reading and listening to comments in English in their study and work.¹²⁴

In <https://sites.google.com/view/theeltpractitioner/archive/2018/volume-v-number-iii/2-role-of-materials-development-for-english-language-learning-and-teaching>, it is stated that there are at least two things to be elaborated about materials development. It is both a field of study and a practical undertaking. As a field of study, it studies the principles and procedures of the design, implementation, and evaluation of language teaching materials. As a practical undertaking, it involves the production, evaluation, and adaptation of language

¹²⁴ Ibid.

teaching materials, by teachers for their own classrooms and by materials writers for sale or distribution. As a field of study, materials development studies the principles and procedures of the design, implementation, and evaluation of language teaching materials. As a practical undertaking materials development is anything where writers or learners provide sources of language input, and exploit it in ways that maximise the likelihood of intake and stimulates output. Learning or teaching materials, in practice, can be developed or produced by evaluating learning materials, adapting, supplementing and creating own materials. Teachers usually use any textbook available to teach their students. What they can do is usually trying to evaluate the textbook they have to use to teach their students. In evaluating the textbook, teachers observe what works and what does not work and they add their own style or preference and interpretation to the textbook. If they think that the textbook is in line with the curriculum or syllabus, the textbook can be used to teach their students.

Teachers will evaluate and select textbooks according to how appropriate they seem for the given context. Well-designed textbooks can support inexperienced teachers a lot because they act as training materials. Textbooks can also be evaluated by exploring teachers and learners experiences and opinions about the textbooks as used in the classroom. This evaluation can result in the most effective textbooks which can be used in the classroom. This result, however, cannot be valid for different students and teachers and in different time. Another thing to remember is that adapting teaching materials, especially from the authentic text, does not always work well. In adapting the authentic text to become learning materials, a teacher has to remember the English that the students have to learn from the adapted texts. Still, we have to allow the students to have an effort to cope with more challenges from the adapted texts. A teacher has to be conscious that gradually the students will have to struggle themselves to face the authentic texts without having any adaptation.

Supplementing the existing textbooks used to teach is another effort to cover the weakness of the available textbooks that does not match with the syllabus or curriculum or objectives of the teaching or learning. The supplementary teaching or learning materials can vary according to the availability of the materials or the creativity of the teachers. Creating own materials is the teachers last effort to develop learning materials instead of adapting or supplementing the existing textbooks or authentic texts. There should be fundamental bases in order to create own materials, among others, teaching objectives or instructional goals, student's needs, and topic-based planning.¹²⁵

Dick and Carey suggest that there is a long procedure to develop instructional materials after identifying instructional goals. There are five steps between identifying instructional goal up to the instructional materials development: conducting instructional analysis, identifying entry behaviours and characteristics, writing performance objectives, developing criterion-referenced test items, and developing instructional strategy. The next step is developing and selecting instructional materials. With these steps Dick and Carey want to emphasize on the accuracy of all the components in the system approach of instructional design, including the accuracy of developing and selecting instructional materials.¹²⁶

A teacher can also develop learning materials on the basis of the student's needs. This situation would happen when a teacher is facing new students. In order to meet the students' needs of English, an English teacher has to find out what English competence the students want to achieve. After knowing the English competence that the students want to achieve, the teacher develops the learning materials to help the learners achieve the English competence they

¹²⁵ "Role-of-Materials-Development-for-English-Language-Learning-and-Teaching," last modified 2018, <https://sites.google.com/view/theeltpractitioner/archive/2018/volume-v-number-iii/2-role-of-materials-development-for-english-language-learning-and-teaching>.

¹²⁶ Dick, Carey, and Carey, *The Systematic Design of Instruction*. 6th.

want. Creating own materials based on Topic-based planning means that the materials developed for the learning materials should be based on the topic already chosen and, therefore, all the activities in all areas of the curriculum should be related to that one broad topic.

D. Types of Teaching Materials

Broadly speaking, it can be argued that instructional materials are knowledge, skills, and attitudes that must be mastered by students in order to meet the set competency standards. According to Tomlinson, materials is used to refer to anything which is used by the teachers or the learners to facilitate the learning of a language. Materials could obviously be cassettes, videos, CD- Rom, dictionaries, grammar books, readers, workbook, or photo copied exercises.¹²⁷

Related to the explanation above, Rochmawati divides the materials into some types as follows:

1. Printed materials, for example textbook, student's worksheet, pictures, photographs, newspapers, magazines, etc.
2. Audio materials, for example cassette and compact disc.
3. Audio visual, for example video compact disc, film.
4. Interactive teaching materials, for example web based learning materials, computer assisted instruction.¹²⁸

Moreover, the teaching materials can be also categorized whether they are authentic or created.

a. Authentic Materials

Authentic or learner-contextualized materials is printed materials used in ways that they would be used in the lives of learners outside of their education classes. For example, the use in teaching of text, photographs, and other teaching resources that are not

¹²⁷ Brian Tomlinson, "Materials Development for Language Learning and Teaching," *Language teaching* 45, no. 2 (2012): 143.

¹²⁸ Rochmawati, *English Curriculum and Material Development*.

especially prepared for pedagogical purposes. There are some strengths and limitations of authentic materials.

b. Created Materials

Created Materials refers to textbook and other specially developed instructional resources. Creating materials that are tuned to the students' needs gives the learning experience more meaningful. Students can relate better when the contents are based on their experience, culture, and beliefs. *Created materials* refers to textbooks and other specially developed instructional resources that have been prepared to include examples of specific grammatical items discourse features. Dialogs in course books, for example, might be specially written to highlight certain grammatical choices or to illustrate specific conversational strategies (<https://www.professorjackrichards.com/using-authentic-materials>).¹²⁹

E. Material Selection

According to Kemp, instructional sources can fulfill the instructional objectives since they are carefully selected and prepared.¹³⁰ In line with Kemp's opinion, Thonis states that the criteria may be used in selecting the materials of reading program for non-native English speakers are the objectives of the program, the nature of the students, the provision of time allotted for individual learners, the articulation status, the management in the classroom, the cultural content and cost.¹³¹

(1) The objective of the program

¹²⁹ “(<https://www.professorjackrichards.com/using-authentic-materials>).”

¹³⁰ Jerrold E Kemp, *Instructional Design: A Plan for Unit and Course Development*. (Los Angeles: Harper Collins Publishers, 1977).

¹³¹ Eleanor Wall Thonis, *Teaching Reading to Non-English Speakers*. (New York: The Mackmillan Company, 1970).

The materials used to introduce the written symbols of English should serve to support the objective of developing both the ability to decode and the ability to get meaning from the print.

(2) The nature of the students

Some aspects of the students such as the physical growth, intellectual potential, emotional stability, social development and customary manner of the students should be considered. Also, teachers should consider the materials which provide for the variety of individual traits which may be found in any class of the students.

(3) The provision of time allotted for individual learners

The materials selected should make the best use of time for teachers and students. The materials permit to engage the students in every activity without wasting and consuming time. In addition to this, teachers should consider the time available for using the materials, the possible adjustment of time needed by individual students, and the realities of classroom time in second language learning.

(4) The articulation status

The materials which serve to carry the reading program should be selected upon the basis of their relatedness within a total program. When the materials are selected for use in the classroom, the following questions need to be asked: How do the materials follow what the students have already experienced? How do the materials match with what the students anticipated to learn after they move ahead to the next class? How do the materials support the reading the students may have to do in other subjects?

(5) The management in the classroom

The choice of materials should consider factors which can attract the students and teachers. The materials may be selected because they are attractive to the students and the teachers, they are easily seen and readily understood, they are accessible and available

when needed for a particular purpose, and they may be presented simply and conveniently stored.

(6) The cultural content

The materials to be used for boys and girls who may not be completely familiar with the many social and cultural aspects of the English speaking people should be both representative and fair. In each cultural setting there are many roles and status across a variety of social and economic cross-section. As students use the materials, they should encounter authentic situation, real people, and factual descriptions of the many different people, objects and events which make up the cultural group.

(7) The cost

The materials should be selected on the basis of financial capabilities. Cost must be weighed in terms of the capacities, expectations and educational objectives of the school and community.

Similarly, Nunan states that when selecting materials it is important to match the materials with the goals and objectives of the program, and to ensure that they are consistent with one's beliefs about the nature of language and learning, as well as with one's learner's attitude, beliefs and preferences.¹³²

F. Criteria of a Text Selection

According to Nutall, in selecting a text for reading materials, a number of considerations should be given. The text that is selected should meet the criteria of readability, suitability, and exploitability.¹³³

Readability is the combination of structural and lexical difficulty. The text should be at appropriate level both of linguistic and conceptual difficulty. The selection of a text should be at the right level for students. However, since no class is ever entirely

¹³² Nunan, *Language Teaching Methodology: A Textbook for Teachers*.

¹³³ Nuttall, *Teaching Reading Skills in a Foreign Language*.

homogeneous it is suggested that the text should suit most of the students in that particular group.

Suitability means the text should be relevant for students. The text should be chosen based on the field of the students themselves. By then it is expected that the reading tastes of the students could be generally fulfilled.

Exploitability means a text which leads to good questioning or which might be made use of to develop student's competence as readers is better to use. It also means that the text can be used to develop skills and strategies the students need as well as it should involve appropriate reading task.

In addition to selecting a text as a material for reading, Day proposes some criteria which are almost similar to Nutall. The criteria are: interest, readability, exploitability, topic and appearance.¹³⁴

In selecting a text, consideration should be given to interest if the course is to yield positive result. For the sake of the students, the lecturers should remember that the most important factor in selecting a reading article is interest.

The readability ranks are one of the most important considerations in selecting a reading passage among others. It consists of lexical knowledge, syntactic appropriateness, organization discourse phenomena and length.

Exploitability as the facilitation of learning is a key factor in selecting a reading passage. One way to determine the exploitability of a passage is to do exercise and activities in reading lesson. Exploitability shows the implication that the text can be used to develop the skill and strategy that the students need to comprehend the text easier.

So far, Tomlinson and Masihura state that there are many criteria to be used for selecting texts, but the most important are: (1) does the text still engage the learners cognitively and affectively? (2) is

¹³⁴ R.R. Day, "Selecting a Passage for The EFL Reading Class.," *English Teaching Forum* 32, no. 1 (1994): 20–24.

the text likely to engage most of the target learners cognitively and affectively? and (3) are the target learners likely to be able to connect the text to their lives?¹³⁵

The topic of a reading is an important factor to consider. The lecturer may feel that a wide variety of topics would be helpful to maintain the students' interest and motivation.

The appearance which includes lay out, type-size, and font is also important to be borne in mind. They are important for beginning learners and beneficial for the students. The reading teacher should examine the article to see whether the lay out is beneficial or harmful. They should be clear and attractive to aid the students in decoding process of reading.

Another important consideration in selecting a text for reading materials is authenticity of the text. The term authentic in this study refers to materials which are used in genuine communication in the real world. Authentic materials are suitable means of exploring the students to the genuine use of English for communication. Authentic materials such as textbook and journals can provide valuable support to the comprehension of the major content subject the students have to study.

Furthermore, Arias states that selecting reading materials for any particular ESL/EFL class must be a thoughtful process rather than a random one. The students must be actively involved in this process if teachers want to adopt appropriate reading materials for the class. In this case there will be certain factors that need to be considered by the teachers when preparing material for ESL/EFL classes. The teachers who decide to select reading materials wisely need to devote some of their valuable time to analyzing each one of these aspects. If teachers successfully select a variety of appropriate texts, the students will perceive reading as an interesting and valuable activity. On the contrary, if the passage chosen is inappropriate for

¹³⁵ Tomlinson and Masuhara, *Developing Language Course Materials*Materials: RELC Portfolio Series 11.

whatever reason, the chances of success for that particular lesson are substantially lessened.¹³⁶ Next, Arias, taking some experts ideas asserts that the most significant factors in the reading selection process are related to the students: the students' level, interests, needs, and background knowledge.¹³⁷

a. Students' Level

The instructor needs to be aware of the students' level and acknowledge that fact when selecting the materials for the reading class. Researchers such as Melvin & Stout, Lotherington, and Fox suggest that the educator needs to know which materials are suitable for the students' level. The material that is selected for the ESL/EFL class should not go beyond the students' level. The level of the students will influence the selection of material.

Asking the students to read material that goes beyond their level might be counter productive since learners may feel that they are simply incapable of reading in the target language. Some researchers have suggested that one alternative for providing the students with appropriate reading materials is simplifying the texts in order to make them accessible for the students. However, this idea has received little support from field researchers and professionals.

It is better to simplify the reading process rather than the text. Instructors can provide the students with a variety of reading techniques in order to facilitate the reading comprehension process. Instructors should start using less complicated texts, selections from local newspapers (always avoiding texts oriented toward tourists with whom students do not identify) and popular magazines. Later they can use more complex texts as the students increase their reading fluency, as well as texts with different degrees of difficulty. Once the instructor has determined the students' level, she can choose

¹³⁶ Ivannia Jiménez Arias, "Selecting Reading Materials Wisely," *Letras*, no. 41 (2007): 131–151.

¹³⁷ *Ibid.*

appropriate sources to select reading materials for each particular group of students. Those teachers who are willing to select reading materials wisely can never neglect students' interests.

b. Students' Interests

The materials selected for the ESL/EFL reading class ought to satisfy students' interests. No matter how difficult or easy a text might be, it would be boring or difficult to read if it is not interesting to the learner. The first step for material selection is to find material that the students are likely to be interested in. Material for the ESL/EFL class should be selected on the basis of students' interests. With the purpose of finding out students' interests, the instructor should make an assessment about the students' interests and needs at the beginning of the period. Through a survey, interviews or just an informal discussion, the instructor can ask the students to suggest appropriate topics for the class. They should also be encouraged to bring their own contributions to the class. Educators can make the students responsible for selecting relevant reading materials in order to create a file of readings available for all the students in the class. Interest is closely related to motivation. When the topic of a passage is not of interest to students, their motivation to read is substantially lessened. Without this motivation, it is exceedingly difficult to meet one of the generally accepted aims of a reading program, namely to help get the learners to read in English on their own, outside the reading classroom. Considering the students' interests in the reading selection process is as important as exploring the students' needs.

c. Students' Needs

There has been a great deal of agreement among researchers about the importance of considering students' needs in the material selection process for the ESL/EFL reading class. That the teachers should always discover the students' needs before making any decisions about the course content. Teacher should be aware of the students' needs to be able to help them fulfill these needs by

providing appropriate materials. There are certain needs that all the students have in addition to their individual needs. For instance, all students need to be able to read fast, to time themselves, to know basic reading techniques, and others. Educators must then take into account common needs as well as the individual needs in the process of material selection. The mismatch between students' expectations in regards to their needs and interests can result in students' frustration, which might imply failure on a reading course.

d. Students ' Background Knowledge

Another significant criterion for selecting appropriate material for the EFL reading class is students' background knowledge. In order to provide the students with suitable material, the instructor must be familiar with the students' background knowledge. Research findings have emphasized the importance of considering this aspect in the material selection process. Reading cannot be separated from the readers' previous knowledge. The lack of background knowledge may cause more difficulties for the ESL reader than language complexity does. Likewise, background knowledge is an important part of the students' ability to read and understand a particular text. It is possible and not uncommon for a reader to understand every word in a passage, without really understanding what the words mean. For this reason, the role of the teacher is to consider students' background knowledge when selecting materials for the reading class. This does not imply that it is not possible to use texts for which the students or the instructor himself lack the background knowledge, but rather that it is the teacher's responsibility to provide the students with the information required for comprehending a particular text. Pre-reading activities are particularly useful for this purpose. In other words, the teacher must be aware of the need to facilitate the reading comprehension process by either giving the students the background knowledge along with the reading material, or requiring them to acquire it by their own means, for example, doing some kind of informal research.

To sum up, the issue of students' background knowledge should be considered in the text selection process and course design due to the fact that background knowledge plays a critical role in the reading comprehension process. This aspect is particularly important when the students need to read in a second or foreign language, for they possibly lack the necessary understanding of the target culture.

CHAPTER VII ENGLISH FOR SPECIFIC PURPOSES (ESP)

A. An Overview of English for Specific Purposes (ESP)

English for specific purposes (ESP) is an admirable movement in English language education that is opening up rich opportunities for English teachers and researchers in new professional domain. The growing demand for highly proficient speakers of specialized, academic, and workplace English is drawing increasingly large numbers of teachers into the ESP profession and awarding them higher salaries and prestige than were previously given to language instructor.¹³⁸ This movement began in the 1960s as a result of developments in Linguistics and Educational Psychology. As an approach, ESP is based on designing courses to meet specific needs of the learners. Richard argues that the ESP approach to language teaching began as a response to a number of practical concerns such as the need to prepare growing numbers of non-English background students for study at American and British universities from the 1950s, the need to prepare materials to teach students who had already mastered general English, but now needed English for use in employment, such as non-English background doctors, nurses, engineers, and scientist, the need for materials for people needing English for business purposes, and the need to teach immigrants the language needed to deal with job situation.¹³⁹

As English has been accepted as the international language, learners of English then know specifically why they learn the language. In relation to the students, it is the students whose course of study included textbooks and journals available in the language that force them to master English. The general effect of all this

¹³⁸ T. Orr, *English for Specific Purposes* (Virginia: Teacher of English to Speakers of Other Languages, Inc., 2002).

¹³⁹ Jack C Richards, *Curriculum Development in Language Teaching* (Cambridge: Cambridge University Press, 2001).

development is to have language teaching profession to deliver the required specific English. By this it was felt that to have English for specific purpose is part of English that will be most useful to students in their pursuit of their academic goal. ESP has become more and more popular among the teachers and practitioners recently since there is an expansion of demand for English to suit particular needs and development in the field of linguistics and educational psychology.

Different students have different needs and interest which would have an importance influence to their motivation to learn English. In the case of UIN Mataram, the students need to learn English as a tool for the process of transferring knowledge from any English sources relevant to their area of study especially written or printed, not for the purpose of mastering the English language itself.

The growth of ESP was brought about by a combination of two important factors: the expansion of the demand for English to suit particular need and the development in the field of linguistics and psychology.¹⁴⁰ Both factors seem to point toward the need for increased specialization in language learning, that ESP is created. Thus, the assumption that underlies the ESP approach is that the clear relevance of the English course to their needs would improve the students' motivation that it finally makes learning better and faster.

The ESP that is primarily taught or researched consists of spoken and written discourse in academic and workplace settings, which is unfamiliar to most non-native speakers and thus requires special training. Specific purpose English includes not only knowledge of a specific part of the English language but also competency in the skill required to use this language, as well as sufficient understanding of the context within which it is situated.

¹⁴⁰ M.K. Morray, "INELEC. Team Work in EST Program," *English Teaching Forum* 19, no. 1 (1991): 18–21.

Hutchinson and Waters distinguish ESP into two main branches: English for Academic Purposes (EAP) and English for Occupational Purposes (EOP). Since the growing industry the offshoot of the labeling has flourished widely such as: EBP (English for Business Purposes), EEP (English for Educational Purposes), ERP (English for Recreational Purposes), etc. While, MC Donough (1984) groups the focus of ESP into three courses: research, project and geography. Many courses are begun with the word 'English': English for Secretary, English for waiters, English for Nurses, English for Doctors, etc. Then, of the two branches of ESP that has been mentioned, English for Academic Purposes (EAP) is the concern of this study i.e. English that is designed to meet the specified needs of the students of Economic Department at UIN Mataram in which the material (the content) is more related to their discipline and it is restricted to reading skill to be learned.

B. Definition of English for Specific Purposes (ESP)

The term English for Specific Purpose (ESP) brings a variety of definitions. Traditionally, the terms ESP is has been used to refer to courses aiming at teaching the English language needed for specific situation, mainly related to academic (EAP) or occupational (EOP) contexts. Therefore, an ESP course is developed based on the analysis of purposes and needs and the activities for which English is needed.

Hutchinson and Waters define ESP as an approach to language learning, whereby the method and content depend on learners' specific needs.¹⁴¹ Rahman tried to give interpretation for this definition by saying that ESP does not involve a particular kind of language, teaching material or methodology.¹⁴² They suggest that the

¹⁴¹ Huchinson and Waters, *English for Specific Purposes: A Learning-Centered Approach*.

¹⁴² Momtazur Rahman, "English for Specific Purposes (ESP): A Holistic Review.," *Universal Journal of Educational Research* 3, no. 1 (2015): 24–31.

foundation of ESP involves the learners, the language required and the learning contexts which are based on the primacy of need in ESP. Strevens formulates a definition of ESP, which makes a distinction between four absolute characteristics and two variable characteristics. The four absolute characteristics are: (1) designed to meet specified needs of the learner, (2) related in content (i. e., in its themes and topics) to particular disciplines, occupations and activities, (3) centered on the language appropriate to those activities in syntax, lexis, discourse, semantics, etc., and analysis of this discourse, and (4) in contrast with “General English. While, the two variables are: (1) restricted as to the language skills to be learned (e.g. reading only) and (2) not taught according to any pre-ordained methodology.¹⁴³

Dudley-Evans and St. John in Rashtchi et al. provide a more comprehensive view by describing “absolute characteristics” and “variable characteristics” as the two essential features of ESP courses.¹⁴⁴ Absolute characteristics emphasize that ESP is a needs-specific course focusing on the language, skills, discourse, and genre-appropriate to the activities designed based on the underlying methodology of the discipline it serves. On the other hand, variable characteristics consider ESP as a course developed for adult learners in intermediate or advanced levels designed for specific disciplines based on a methodology different from General English. Here are detail definition of ESP, in terms of absolute and variable characteristics given by Dudley-Evans:

➔ **Absolute Characteristics**

1. ESP is defined to meet specific needs of the learners
2. ESP makes use of underlying methodology and activities of the discipline it serves

¹⁴³ Peter Strevens, “ESP after Twenty Years: A Reappraisal,” *ESP: State of the Art* (1988).

¹⁴⁴ Mojgan Rashtchi and Reza Porkar, “ESP Courses and Identity Formation: The Case of Introvert Students,” *International Linguistics Research* 3, no. 1 (2020): p29–p29.

3. ESP is centered on the language appropriate to these activities in terms of grammar, lexis, register, study skills, discourse and genre.

➤ Variable Characteristics

1. ESP may be related to or designed for specific disciplines.
2. ESP may use, in specific teaching situations, a different methodology from that of General English.
3. ESP is likely to be designed for adult learners, either at a tertiary level institution or in a professional work situation. It could, however, be for learners at secondary school level.
4. ESP is generally designed for intermediate or advanced students.
5. Most ESP courses assume some basic knowledge of the language systems.

To sum up, based on the definitions given, ESP is understood to be about preparing learners to use English within academic, professional, or workplace environments, where the language is going to be used. In ESP, English is learnt not for its own sake or for the sake of gaining a general education but to smooth the path to entry or greater linguistic efficiency in particular environments.¹⁴⁵ Specifically, ESP in the context of reading instruction is an approach, which is based on the learners' need to understand the message, conveyed in the reading materials presented to them. From the explanations above, ESP can be defined as the branch of English learning where the material and the activity focuses on the learners' specific needs. Basturkmen states that ESP is a branch of English language learning which focuses on the central importance of learners, their need and interest, and comes into being and gradually developed into a multilayered language approach primarily based on learners' specific needs required by their professions or occupations.¹⁴⁶

¹⁴⁵ Helen Basturkmen, "ESP Teacher Education Needs," *Language Teaching* 52, no. 3 (2019): 318–330.

¹⁴⁶ Helen Basturkmen, *Developing Courses in English for Specific Purposes* (Springer, 2010).

C. Objectives in Teaching English for Specific Purposes (ESP)

There are several aims of teaching ESP as a course. In general, the aim of ESP is to develop the language potentialities of the students who need the language to update knowledge in their area of study. According to Hutchinson and Waters states that the purpose of an ESP course is to enable learners to function adequately in a target situation.¹⁴⁷ Another purpose of designing ESP course is to make the language specifically taught fulfill the language needed in the field to be studied by the learners. Therefore, implementation of ESP is crucial in order to equip students with appropriate language skill. Nevertheless, the implementation may present challenges for the teachers as designing ESP courses require profound research and significant amount of time. The teaching of English for specific purposes (ESP) is also aimed to equip learners with a certain English proficiency level for a situation where the language is going to be used. Concerning ESP, Basturkmen states five broad objectives of ESP on which specific teaching process is based and should be reached. The five objective are the following.

1. To reveal subject-specific language use.

This objective aims to demonstrate to the learners how the language is used in the target setting.

2. To develop target performance competencies.

This objective is concerned with what learners do with language and the needed skills to be competent. “This orientation can be categorized as a proficiency objective.

3. To teach underlying knowledge.

The aim is to focus on developing students’ knowledge of fields of study or work in addition to their language skills. The objective

¹⁴⁷ Hutchinson and Waters, *English for Specific Purposes: A Learning-Centered Approach*.

of teaching underlying knowledge can be classified as a cultural knowledge objective.

4. To develop strategic competence

Strategic competence is the link between context of situation and language knowledge and enables successful and efficient communication.

5. To foster critical awareness.

This objective can be linked to the cultural knowledge and affective objectives and aims at making students conscious and culturally aware of the target situation.¹⁴⁸

D. Needs Analysis in ESP

The identification of the needs of the students is considered important since the actual success of a program is partly determined by the result of it. In order to suit the needs of the students and their background knowledge, the development of reading comprehension materials for the students of UIN Mataram was based on the result of the needs analysis.

Richard argues that procedures used to collect information about students' needs are known as needs analysis.¹⁴⁹ Learning needs refer to what the learner needs to do in order to learn. It is concerned with the method and activities in a learning process. To decide the method and activities, the teacher should understand the learning goals, the preferred styles of learning, and the commitment to learn of the learners. Needs analysis is conducted to obtain information about the type of needs on the basis of the existing learning teaching situation and the needs of the students. Meanwhile, Morales et al. asserts that an effort to know needs of a group of

¹⁴⁸ Basturkmen, "ESP Teacher Education Needs."

¹⁴⁹ Richards, *Curriculum Development in Language Teaching*.

learners to learn English is called a needs analysis or needs assessment.¹⁵⁰

Needs analysis is necessary for the institutions to design or develop the English curriculum to find out a set of competencies needed by the students. Needs analysis to find specific needs for the students in the institution may direct the institution to an English program called English for Specific Purposes (ESP). Kaur describes needs analysis helps teachers to select appropriate tasks and content and teachers' statements of goals and to provide a better understanding of the purpose of instruction for the learners.¹⁵¹ Therefore, needs analysis is the base on which curriculum content, teaching materials and methods are constructed. This gives way to enhancing the students' motivation and achievement as a result.¹⁵²

To sum up, needs analysis is the systematic data collection and examining of all subjective and objective information required to describe and validate curriculum goals that support the language learning needs of learners within the context of the institutions that affect the learning and teaching situation.¹⁵³

Needs analysis in language teaching may be used for a number of different purposes. Richard gives some examples for which needs analysis can be purposedful, namely to find out what language skills a learner needs in order to perform a particular role, such as sales manager, tour guide, or university student, to help determine if an

¹⁵⁰ A.M. Quiroga Rodríguez & C.L.C. Morales, L.Y. Oliveros Urrego and P.A. Rodríguez González., "English Curriculum Proposal Based on a Needs Analysis Study of Efl Learners in Elementary Grades at Escuela Normal Superior Distrital María Montessorri," *ENGLISH EDUCATION JOURNAL (EEJ)*, 9, no. 4 (2010): 589–613.

¹⁵¹ Sarjit Kaur, "ESP Course Design: Matching Learner Needs to Aims," *English for Specific Purposes* 6, no. 1 (2007): 25–37.

¹⁵² Simion Minodora Otilia and C Brancusi, "Needs Analysis in English for Specific Purposes," *Annals of the Constantin Brâncuși University of Târgu Jiu, Economy Series* 1, no. 2 (2015): 54–55.

¹⁵³ H. Douglas Brown, *Teaching by Principles: An Interactive Approach to Language Pedagogy*.

existing course adequately addresses the needs of potential students, to determine which students from a group are most in need of training in particular language skills, to identify a change of direction that people in a reference group feel is important, to identify a gap between what students are able to do and what they need to be able to do, and to collect information about a particular problem learners are experiencing. The main purpose of the needs analysis should be to match the beliefs, expectations and perceptions of teachers or administrators or language curriculums with the needs of learners. Needs analysis may greatly help writers to have an outline of principled approaches to developing ELT materials. To have a principled route map for doing needs analysis, Tomlinson and Masuhara discusses this issue as: Whose needs analysis? How are 'needs' defined in the literature? They seem to be defined in terms of: (a) ownership (whose needs are they?) (b) kinds (what kinds of needs are identified) (c) sources (what are the sources for the need?) She draws a table in which she lists the needs identified in needs analysis literature to be expanded.¹⁵⁴

In order to get information about the needs of the students of Economics Department at UIN Mataram, questionnaire and interview were used. All the data collected from these instruments were used to identify the needs of the students on the material developed. In relation to the finding of the students' needs, Hutchinson and Waters suggest that it is a normal practice to involve both students and lecturers to ask about their needs.¹⁵⁵ Regarding to this, the students of Economics Departments, UIN Mataram (i.e. those who are taking and those who have taken reading comprehension course) and the lecturers at UIN Mataram (i.e. the

¹⁵⁴ Tomlinson and Masuhara, *Developing Language Course Materials*Materials: RELC Portfolio Series 11.

¹⁵⁵ Huchinson and Waters, *English for Specific Purposes: A Learning-Centered Approach*.

lecturer of English and the lecturer of reading comprehension course) were confirmed to obtain data about needs.

There is a close relation between ESP and needs analysis. The key stage in ESP is needs analysis. Needs analysis is the corner stone of ESP and leads to a focused course. According to Robinson needs analysis is generally regarded as critical to ESP, although ESP is by no means the only educational enterprise which makes use of it.¹⁵⁶ Strevens suggests that needs analysis is a necessary first step for specific purposes language teaching; it is more concerned with the nature of scientific discourse.¹⁵⁷ Hutchinson and Waters argue that any language course should be based on needs analysis.¹⁵⁸ Hamp-Therefore, needs analysis is fundamental component to an ESP or EAP approach in term of course design.

It is obvious that needs analysis is a very crucial first step prior to designing and developing a language course, producing materials for teaching and learning, and developing language test. It is important for ESP practitioners to carry out needs analysis study prior to developing and designing an ESP syllabus, a course, selecting a teaching approach and other relevant processes that require needs analysis. Generally speaking, where there is no needs analysis, there is no ESP course. In summary, a language needs analysis is a process that must be conducted prior to a language course and syllabus design, materials selection, teaching and learning methodology and evaluation. The ESP practitioners should be able to utilize the results of needs analysis research which he or she conducts to develop a language course or training program that is suitable, practical and successful for a particular context.

In an ideal situation, the material developed should reflect the students' needs to study English. Different types of students have

¹⁵⁶ Robinson, *Curriculum Evaluation for Life Long Education*.

¹⁵⁷ Strevens, "ESP after Twenty Years: A Reappraisal."

¹⁵⁸ Hutchinson and Waters, *English for Specific Purposes: A Learning-Centered Approach*.

different needs and what they are taught should be restricted to what they need. The identification of the needs of the students is considered important since the actual success of a program is partly determined by the result of it. In order to suit the needs of the students and their background knowledge, the development of reading comprehension materials for the students of UIN Mataram was based on the result of the needs analysis. Richard states that procedures used to collect information about students' needs are known as needs analysis. Learning needs refer to what the learner needs to do in order to learn. It is concerned with the method and activities in a learning process. To decide the method and activities, the teacher should understand the learning goals, the preferred styles of learning, and the commitment to learn of the learners. Needs analysis is conducted to obtain information about the type of needs on the basis of the existing learning teaching situation and the needs of the students.

Meanwhile, Morales et al. asserts that an effort to know needs of a group of learners to learn English is called a needs analysis or needs assessment.¹⁵⁹ Needs analysis is necessary for the institutions to design or develop the English curriculum to find out a set of competencies needed by the students. Needs analysis to find specific needs for the students in the institution may direct the institution to an English program called English for Specific Purposes (ESP). Needs analysis in language teaching may be used for a number of different purposes.

Needs analysis makes use of both subjective and objective information (e.g. data from questionnaires, tests, interviews, observation) and seeks to obtain information on: the situations in which a language will be used (including who it will be used with), the

¹⁵⁹ C.L.C. Morales, L.Y. Oliveros Urrego and P.A. Rodríguez González., "English Curriculum Proposal Based on a Needs Analysis Study of Efl Learners in Elementary Grades at Escuela Normal Superior Distrital María Montessorri."

objectives and purposes for which the language is needed, the types of communication that will be used (e.g. written, spoken, formal, informal), the level of proficiency that will be required. Needs assessment is a part of curriculum development and is normally required before a syllabus can be developed for language teaching. There are two needs in language teaching, namely the followings.

a. Target Needs

Target needs is what the learners need to do in the target situation or in real-life conversation and condition. Target situation: the situation or setting in which the student will have to use the target language. This may be a study target situation or work situation or any context in which the learner needs to use the language. Analysis of the communicative and linguistic demands of the target situation is an essential phase in the needs analysis. There are three aspects on target needs; Necessities: what the learner has to know in order to function effectively in the target situation. Lacks the gap between necessities and what the learners have already known. Wants: what the learners want to know During need analysis, this information can be gathered by using questionnaires, interview, observation, data collection, informal consultation. The information is related to the individual expectation of learning English, the linguistic features of the target situation (language items, skills, knowledge, etc.).

b. Learning Needs

Learning needs is what the learners need to do in order to learn, standardized or based on the current curriculum of the program. This need is related to how learners need to do in order to learn. How the learners need to learn There are many teaching sources for English language teaching, however the materials often not suitable for the cultural and idea of the learners. English is not free from the culture, which may lead to a conflict between English

learner culture and English culture itself from the teaching materials. Thus, specified materials need to be developed to answer the conflict which may occur. This research intended to give an analysis of what kind of materials needed in the Muhammadiyah junior high school in English language teaching for reading skill.

In order to get information about the needs of the students of UIN Mataram, questionnaire and interview were used. All the data collected from these instruments were used to identify the needs of the students on the material developed. In relation to the finding of the students' needs, a number of sources can be involved such as the learners, people working or studying in the field, ex-students, documents relevant to the field, clients, employers, colleagues and ESP research in the field. Furthermore, Hutchinson and Waters suggest that it is a normal practice to involve both students and lecturers to ask about their needs. Regarding to this, the students of Economics Departments, UIN Mataram (i.e. those who are taking and those who have taken reading comprehension course) and the lecturers at UIN Mataram (i.e. the lecturer of English and the lecturer of reading comprehension course) were confirmed to obtain data about needs.

E. The Needs of Students in ESP Reading Class

ESP has become more and more popular among the teachers and practitioners recently since there is an expansion of demand for English to suit particular needs and development in the field of linguistics and educational psychology. However, it is important to know that teaching ESP is not a matter of teaching specialized varieties of English. The fact that language is used for a specific purpose does not imply that it is a special form of the language, different in kind from other forms. ESP is based on principles of effective and efficient learning. Though the content subject may vary, there is no reason to suppose that the process of learning ESP should

be different from learning general English. In other words, ESP could be used in the learning of any kind of English learning as well.

A major trend in the teaching of English as a foreign language is the integration of major content subject with the instruction of the foreign language. The integration enables students to develop academic knowledge and skills in the major content subject while they acquire the academic language needed to succeed in the university level. Hamayan states that the integration of major content subject and language also allows for the development of thinking skills which has become current focus of the English as a foreign language interaction.¹⁶⁰

Reading in ESP is reading authentic texts. The texts can be from books, magazines, newspapers, journals and others which are usable and focused on the materials studied by the students. It is hoped that the students are able to update their specific knowledge in their specific area and have better understanding of their subject matter.

F. Developing a Model of ESP Reading Materials

The selection of materials is a big decision, because it is the materials which determine later on the vocabulary, language structure and concepts which make up the reading materials. The greater part of the students' work in their studies will be on reading textbook and journals, and consequently, the ESP course must lay heavy emphasis on reading comprehension of textbooks and journals.

Developing ESP reading materials is one of the most characteristic features of ESP in practice. According to Hutchinson and Waters, a model of ESP reading materials design should include four elements namely input, major content subject focus, language

¹⁶⁰ E. Hamayan, *Current Trend in ESL Curriculum. Second Language Curriculum. Resource Handbook. A Practical Guide for K-12 ESL Programs* (New York: Kraus International Publications, 1993., 1993).

focus and task.¹⁶¹ The four elements are combined in the model as depicted in Figure 2.1.

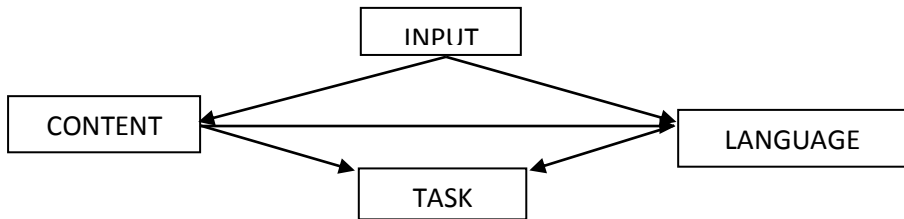

Figure 2.1 The Hutchinson and Waters model for designing ESP Reading Materials

The input provides a number of things, such as new language items, correct models of language use, and opportunities for students to use their information processing skill and to use their existing knowledge both of the language and the major content subject.

Major content subject focus helps the students identify vocabulary and other language components and the context in which they are used. The students bring to the ESP class a reason for learning and a context for using English, knowledge of the major content subjects and well-developed strategies. ESP courses are developed through a need assessment that identifies what the students need to do in English (task), the context in which they will do it (text) and what their current level of English is.

In language focus our aim is to enable the students to use language, but it is not fair to give them communicative task and activities for which they do not have enough of the necessary language knowledge. Good materials should involve both opportunities for structural construction and content. In this part, the students have a chance to take the language into pieces, study how it works and practice putting it back together again.

¹⁶¹ Huchinson and Waters, *English for Specific Purposes: A Learning-Centered Approach*.

Task is intended to give the students chance to learn the language in the context of the text. Material should be developed in which the students use the major content subject and language knowledge they have build up through the unit.

The lecturer's use of the materials will influence the learning outcomes in the classroom. The teachers should be able to choose as appropriate as possible the materials for their students. Again the need of the students should become the main concerns of the teachers.

CHAPTER VIII PREVIOUS RELATED STUDIES

A. Review of Previous Related Studies

There are a lot of studies about material development which have been done previously, some of which can be much help in developing the English course material in this study. The research findings reviewed in this section are limited to material development especially in reading.

Susila developed reading materials for Economic students at Muhammdiah University of Bengkulu.¹⁶² In her opinion, one of the factors which causes the failure of learning English is the use of irrelevant materials. Since materials are the responsibility of teachers to improve, she developed the materials which are relevant to the students' need as an alternative to solve the problem. By providing the students with relevant materials she hoped that the students are motivated to learn English and the achievement of the students can be improved. In doing her job, some important principles are worth considering. The principles are from Nunan which states that the materials should be able to encourage the students to apply knowledge, and skills they get in the classroom to the real life situation outside the classroom, and from Dick and Carey from which she adopts the procedure in developing the materials.

Halim also developed reading comprehension materials for graduate students of the State University of Malang.¹⁶³ Realizing the importance of textbooks in English for graduate students and the failure of some students to finish their study in due time because of their poor reading ability make her think it is necessary to develop good reading comprehension materials for the graduate students of

¹⁶² D. Susila, "Pengembangan Materi Pengajaran Bahasa Inggris Untuk Mahasiswa Fakultas Ekonomi Universitas Muhammadiyah Bengkulu" (FFS IKIP Malang, 1994).

¹⁶³ T. Halim, "Developing Reading Comprehension Materials for Graduate Students of the State University of Malang" (UM, 1999).

the State University of Malang. She found that the available materials are not well organized and still need revision. In other words, the existing materials are not specifically designed to improve the reading ability in English of the graduate students. She developed the materials by following the procedures suggested by Taba (1962) with the product self-contained and self- instructional module.

Another research was done by Usadiati who developed a model of ESP reading Materials for the Extension Program at the Faculty of Agriculture, Brawijaya University.¹⁶⁴ The reason she pointed out in this study is that the students find it difficult to comprehend relevant textbooks and journals in their major content subject assigned to them, therefore ESP reading materials should be developed to help them. She assumes that the students will have higher motivation and interest in reading English textbooks and journals when the model of ESP reading materials as the one to be developed is suitable to the students' need. The materials are developed based on the content-based approach.

Next, Erlina, et. al. developed English Reading Materials using Whole Language Approach. for undergraduate EFL students of Universitas Islam Negeri (UIN) Raden Fatah Palembang.¹⁶⁵ The main reason for conducting this study was that the results of the preliminary research which showed that the existing materials are not relevant to the students' need, so there is a need for developing new materials based on whole language principles. They developed the materials by adopting Borg and Gall Model (1983) and the framework for teaching materials writing by Jolly & Bolitho (2011). The finding showed that the new developed materials are considered reliable by the experts, students, and lecturers. The materials are also effective in improving students' reading achievement. The 1 product

¹⁶⁴ W. Usadiati, "Developing A Model of ESP Reading Materials for Team-Teaching Using Content Based Approach" (UM, 1999).

¹⁶⁵ Erlina, Mayuni, and Akhadiah, "Whole Language-Based English Reading Materials."

provides rich input of reading strategies, variety of topics, concepts, texts, activities, tasks, and evaluations. Using this product makes reading more holistic and meaningful as it provides integration across language skills and subject areas.

B. Conceptual Framework

One of the ways to improve the quality of learning can be done by providing opportunities for learners to design or develop learning tools, one of which is teaching materials to help teachers and learners carry out learning activities effectively and efficiently. Limitations or weaknesses found in English learning tools at UIN Mataram, which are not in accordance with the needs of students, have not been able to improve student learning outcomes, and have not been able to encourage student motivation and interest in learning English, especially reading learning is used as a consideration for develop learning materials for English reading skills that are believed to solve these problems. In order to obtain a comprehensive picture and understanding of the problem being studied, studies are conducted on various literatures such as books, articles, research reports, papers, and other sources. This study produces a number of concepts, theories, models, and formulations as theoretical support or thinking frameworks in the context of problem solving. Problem solving begins with planning or designing learning materials that are developed using predetermined models and materials that have been prepared in advance. In this case, a preliminary study in the form of a needs analysis is carried out first to gather information about student needs and the results will be used as a basis for designing learning materials. The learning material that has been completed is designed or developed, then validated by experts to assess or evaluate its strengths and weaknesses (validity). Based on the results of the assessment, comments, suggestions, and expert input then the learning tools are revised. After completing the revision, the learning material was tried out in the field to determine its practicality and

effectiveness in learning by involving students and lecturers. Revisions are made again based on the test results to produce the final product. If depicted in chart form, the framework of this research is as follows.

CHAPTER IX RESULTS AND DISCUSSION

A. Research findings

As stated earlier that this study was aimed to develop reading comprehension materials for the students of UIN Mataram in the forms of a textbook. that is relevant to the curriculum and the needs of the students. Furthermore, this chapter presents the result of development which starts from discussing the result of the needs analysis as the basis for designing and developing the materials, continued with discussing the result of the expert validation as the basis to revise the materials, the result of the try-out, also as the basis for revising the materials and it ends with discussing the revision of the tried-out materials. The discussion of the result of the needs analysis covers the result of questionnaire and interview and the development of the first draft of the materials The discussion of the expert validation covers the result of questionnaire and the development of the second draft of the material. While the discussion of the result of the try-out covers the result of the questionnaire, interview, and the development of the third draft of the materials. The followings are the results of the development in details.

1. The Result of the Needs Analysis

The data about the needs of the students was collected through the use of questionnaire and interview. The two instruments contained items about what reading materials the students of UIN Mataram need to learn. Specifically, the questionnaire contained such statements as the sources of the reading materials, the emphasis of the materials (vocabulary, grammar, content), the relevance of the material to the major of the students, and organization of the materials. Meanwhile, the interview consisted of some questions such as the kinds of text used as the materials, organization of the materials, length of the materials, the level of the materials, lay out of the materials, the inclusion of objectives in the materials, the presentation of content, exercises, test on the materials and so on.

In the process of collecting the data, forty nine students in the fourth and sixth semester of UIN Mataram were involved to fill the questionnaire and two lectures of English at UIN Mataram were involved in the interview. The questionnaires were distributed to the students and they should fill in it and for the interview, the researcher conducted a direct and structured interview with the lecturers.

Based on the result of questionnaires distributed to the students and the result of interview conducted with the lecturers, it was found that most of the students (87.76%) agreed to develop reading materials which are suitable with their major content subject namely economic science. Many of them acknowledged that the materials i.e. reading texts that have been taught before were very common and unmatched with their major content subject; therefore, the reading lesson which they once learned have not been able to assist them to comprehend texts or journals written in English. To this agreement, they had the reason that the materials which are suitable with their major content subject enabled them both to develop their academic knowledge in the major content subject and language skills they need to succeed in university. They also stated that when the reading materials developed correspond to their major content subject, they were able to update their specific knowledge in their specific area and had better understanding of their subject matter. According to the result of interview with the lecturers, the reading materials for the students of Economic Department, UIN Mataram ought to be focused on the texts which have relation to economic matters. This was with the consideration that to make the materials more interested, to make students more motivated to learn the materials, and to make the learning more effective.

Still in accordance with the previous findings, the data indicated that 77.55% of the students of Economics Department, UIN Mataram agreed to include list of vocabulary in the reading materials developed. These responses are in line with what the lecturers stated in the interview. The lecturers also suggested providing the students

with list of vocabulary based on the text they are concerned with in order that they can memorize and use the vocabulary, especially those that are related to technical terms in their major content subject, and finally they are able to understand the text easily. For the students, the difficulties in comprehending the texts because of their limited number of vocabulary became the reason why they agreed to complete the text with list of vocabulary. They hoped that the list of vocabulary given can help them understand better the text they are reading and technical items used in their content subject.

Beside the findings above, the data from the questionnaires also demonstrated that the future reading materials should include grammar review. The number of students who agreed with this was 79.59%. In the students' opinion, the grammar review was necessary to be included in the materials because they expected to be able to understand the rules of English language such as how to write good sentences, how to use particular tenses, how to make passive sentences, and so on. Furthermore, they expected that by knowing grammar they want to be able to understand easily the content of the reading texts they are learning. The data on the result of interview with the lecturers also showed that it was important to include the materials with grammar review with the reason that the students must mastery grammar or structure and vocabulary if they want to be able to understand the content of the materials well.

In relation to the above findings, then, most of the students (83.67%) agreed to clarify the content of the materials in the explanation. This was because they find difficulties in understanding structural construction, vocabulary and technical items in scientific textbooks or journals in their area. So far, the lecturers stated that since the comprehension of the content of the materials became the focus in studying textbooks and journals, the reading materials should also include exercises on reading, structure and vocabulary.

Another data also indicated that the materials should be arranged according to the degree of its difficulty. There were 81.63%

students who stated their agreement about this. They had the reason that the materials need to be compiled based on the level of its difficulty in order that they can learn the materials easier and more systematic. Beside, they had the opinion that learning would become more interesting and enjoyable when the materials were taught from the easy to the difficult one. In line with the above findings, the result of interview showed that the lecturers were in agreement with the students' opinion. They stated that the level of difficulty of the materials should be considered when we give lesson to the students so that they correspond to the needs and competence of the students. If not, the students are not interested and become unmotivated to learn the materials because they lack of spirit.

Finally, the interview with lecturers also indicated that since the materials have the purpose to make the instruction clear and focus, it was very important to include instructional objectives on the materials. It was hoped that the students know what they have to learn and the goal of what they are learning.

For more complete, the result of questionnaire can be presented in the table 1 below.

Table 1. The Result of the Needs Analysis

A. The data about agreement to develop materials which are suitable with the major content subject of the students.

Agree	Disagree	Total
87.76%	12.24%	100%

B. The data about agreement to include list of vocabulary in the materials developed.

Agree	Disagree	Total
77.55%	22.44%	100%

C. The data about agreement to include grammar review in the materials developed.

Agree	Disagree	Total
79.59%	20.41%	100%

D. The data about agreement to clarify the content of the materials in the explanation.

Agree	Disagree	Total
83.67%	16.33%	100%

E. The data about agreement to sequence the materials according to its difficulty.

Agree	Disagree	Total
81.63%	18.37%	100%

2. The Draft of the Material Development

Taking the result of the needs analysis into consideration, the first draft of the material was developed. In this case, the draft of the material was developed on the basis of the students' need reflected on the result of the needs analysis. So far, the materials were developed in the form of a textbook containing reading texts and tasks designed for the fourth semester students of UIN Mataram. The materials in the textbook were developed to provide the students with the knowledge of comprehending English textbooks and journals and to introduce to the students English grammatical structures and develop vocabulary of the students. Besides, the

materials were intended to enrich the student's knowledge in their field of study.

There are some steps to do in the process of developing the draft of the material. The first thing to do was to collect texts from a number of sources. Here, the texts were collected from a number of sources such as books, articles, and newspapers. The texts were selected according to the topics to be presented as well as they were adapted as appropriate as possible in order to match with the students' needs. The next thing to do was to formulate the objectives of learning. The objectives are related to what (competencies) the students need to achieve at the end of instruction. They indicate the desirable knowledge, skills, or attitudes to be gained. After the objectives had been formulated, the content of the materials was selected. The content is information conveyed to the students which include reading texts to be learned by the students. Regarding to this, the content of the materials was taken from a number of sources especially those that were related to the student's major content subject. The following thing to do was to create and organize the tasks or activities around the topics of the texts. The tasks were presented in such an integrated way that the students were able to actively participate in the learning teaching process. Here, the tasks were designed to develop the students' ability in the four areas of language skills; listening, speaking, reading, and writing.

The materials were divided into six units based on the topics, namely: economics, central banks, budgets, business, trade, and markets. Each unit consisted of two up to five sections. The unit of economics contained sections such as: macroeconomics vs microeconomics, famous economist: Adam Smith, and the development of economics. The unit of central banks contained sections such as: functions of money, commercial banks, monetary policy and inflation. The unit of budgets contained sections such as: fiscal policy and financial crises. The unit of business contained sections such as: business organization, business enterprise, and

mergers. The unit of trade contained sections such as: international trade, regional trade agreements, a comparison of tariff rates, exchange rates, and economic sanctions. The unit of markets contained sections such as: international trade, regional trade agreement, economic sanctions, and a comparison of tariff rates. Each section contained texts which involved items such as comprehension questions, writing tasks, speaking tasks, listening tasks, vocabulary tasks, grammar reviews, and grammar tasks.

By presenting specific topics to be learned and dividing the topics into units and sections as described above, it was expected that the materials could represent the needs of the students and fulfilled what the students actually need to learn as well as they were able to encourage the students to learn English. On the other hand, with the exploitation of the texts into integrated skill tasks in each unit, there would be a great chance for the students to do various activities and to improve their knowledge in the four skills of English. Finally, the presentation of grammar review and grammar tasks in each unit would give a chance to the students to learn and internalize the model of language use.

3. The Result of the Expert Validation

Expert validation is the process of judging and evaluating the developed materials by experts. This is a preliminary testing by involving some experts to evaluate the developed materials. Also, this was the next process to do after the draft of the material had been developed, aiming to get input and approval from the experts. In line with this, the draft of the materials was consulted to experts: reading expert and content expert. The reading expert was the English lecturer at UIN Mataram and the content expert was the lecturer of specific major content subject at UIN Mataram. At this process, the two experts were given questionnaires to evaluate as well as to give comments and suggestions on the draft of the materials in the hope

that the data obtained from the result of questionnaire can serve as a basis for revising the materials.

a. Reading Expert

From the evaluation done by the reading expert it was found that the draft of the materials which had been developed had a number of good and weak points. In relation to this, a number of important points to be evaluated by the experts are physical appearances of the materials, organization of materials, instructional objectives, topics, list of vocabulary, texts, comprehension questions, grammar review, examples, tasks, directions, coverage of the materials, content of the material, and language.

According to the expert, the good points of the draft were firstly related to the physical appearances of the materials: cover design, letters, typing, spacing, and layout of the materials. She thought that they were attractive, clear, neat, consistent, and appropriate, yet the cover design need to be improved.

The second good points identified by the expert were related to the organization of the materials and the instructional objectives on the materials. She considered that the organization of the materials was attractive, it was appropriately organized in the form of units and sections, and it was logical in terms of tasks order. In addition, she stated that the instructional objectives were clear and they were appropriately stated and ordered. Yet, they need to be completed.

The third good points according to the expert dealt with the topics, list of vocabulary, and the texts presented on the draft. She said that the topics were interesting, various, up-to-date, appropriate to the needs and interest of the students, and relevant to the content subject of the students.

Furthermore, the expert stated that the lists of vocabulary were well-selected, presented in appropriate form, and they were appropriate for the target situation in this case the students of

Economics Department where the materials will be applied, yet some of which need to be redefined. Dealing with the texts, the expert thought the texts could be exploited into tasks. She said that the texts were able to raise the motivation of the students, and that they could develop the reading skills of the students, and fulfilled the reading tastes of the students although some need to be modified.

The fourth good points found on the materials were related to the comprehension questions, the grammar reviews and the tasks. According to the expert, the comprehension questions were comprehensible to the students, appropriate to the given context, helpful to develop the reading skills of the students, and they provided valuable support to the comprehension of the texts, yet some of which need to be revised. She also stated that the grammar reviews presented were relevant to the student's needs, appropriate to the given context, and they were representative of the underlying grammar rules. Furthermore, she stated that the examples given were clear, appropriate, and they could define concepts clearly and adequately. About the tasks, the expert considered that the tasks were appropriate to the given context, communicative, they could be done by the students, they could encourage the involvement of the students, and they could integrate knowledge of the students about the topics and the language they learn.

The fifth good points identified by the expert on the draft were concerned with the directions which were considered clear, appropriate, and they could be understood by the students, the coverage of the materials which was considered relevant and suitable to the needs and interest of the students and it represented the aspects of reading skill, the content of the materials which was considered clear and appropriate, it was logically ordered, it directly related to the objectives of the instruction and it could be understood by the students.

The last good point the expert found on the draft was related to language. According to the expert, the use of language on the

materials was suitable to the level of the students and it could be understood by the students. In addition, the expert stated that the language could become a model of the correct and meaningful grammatical structures, but some of which need to be modified.

Besides the good points described above, there were some weak points the expert identified on the materials, which need to be revised. The first weak point on the draft according to the expert was related to the cover design which was considered unattractive. The second weak point identified by the expert on the draft dealt with the instructional objectives. She said that the formulation of the objectives was not representative in the sense that they did not accommodate some tasks designed on the draft. She suggested that the instructional objectives should be added in order to cover all the tasks.

The second weak point on the draft in the consideration of the expert was related to the lists of vocabulary. The definition of some words and phrases were not appropriate, so the expert recommended that they should be redefined to make it clear and understandable to the students.

The third weak point found by the experts on the draft was related to the texts in that there were many complicated structures existing in the texts. She thought that the structures were somewhat difficult to understand by the students so they gave less valuable support to the comprehension of the texts. The expert suggested modification on the texts for the sake of authenticity of the texts.

The fourth weak point the expert pointed out on the draft was related to the comprehension questions exploited from the texts. Some questions were not formulated appropriately so that they were not clear to the students. The expert recommended that the questions should be revised in order to be understood well by the students.

The fifth weak point according to the experts was related to the use of language on the materials. Although the language in general

could be understood by the students, the expert suggested modification on the language used, especially that in the texts due to its structural complexity.

Additional comments and suggestions given by the reading expert were to give a description about the teaching of English at UIN Mataram, the profile of the students, the student's proficiency in English, and the level of difficulty and vocabulary size of the texts in order that she could evaluate some aspects of validation that she had ignored before.

The expert also suggested revision on the course overview, especially those that were related to course identity, course objectives, topics and subtopics, and the scheme of the topics. Furthermore, she recommended that the draft should be completed with preface and table of contents.

b. Content Expert

Based on the evaluation done by the content expert, there were some good and weak points of the draft developed. Basically, the points to be evaluated by the experts are the as those bu reading experts such as physical appearances of the materials, organization of materials, instructional objectives, topics, list of vocabulary, texts, comprehension questions, grammar review, examples, tasks, etc.

The first good point of the draft according to the expert was related to the physical appearances of the materials: cover design, letters, typing, spacing, and layout of the materials. He stated that they were attractive, clear, neat, consistent, and appropriate but the cover design need to be improved.

The second good point of the draft identified by the expert was related to the instructional objectives. He considered that the instructional objectives were clear and they were appropriately stated and ordered, but they need to be reformulated.

The third good point pointed out by the expert dealt with the topics presented on the draft. He thought that the topics were interesting, various, up-to-date, appropriate to the needs and interest

of the students, and relevant to the content subject of the students, yet most of which need to be rearranged.

Besides showing some good points of the draft, the expert also found some weak points on the draft that need to be taken into account. The first weak point dealt with the instructional objectives. The content expert had the same opinion as the reading expert that the formulation of the objectives did not accommodate some tasks designed on the draft. Because of this, he suggested the objectives to be reformulated in order that they could cover all the tasks.

The second weak point underlined by the expert dealt with the topics presented on the draft. He stated that the arrangement of the topics and the division of the topics into sections were not appropriate. The topics were not appropriately ordered and the sections did not match with the topics. Hence, he suggested the topics to be rearranged into a good and logical order and replace each section on the topics in which it fit.

Another important comment and suggestion given by the content expert was related to the content of the materials. He thought that the content of the materials was good enough in general since the selection of the materials especially the topics and the tasks was interesting and could activate the students in the learning and teaching process. The expert expected that by presenting such materials the students were motivated to learn English and they were able both to increase knowledge in their field of study and improve their English. It is also important to note here that the expert did not give evaluation to all aspects of the developed materials that have been determined before with the reason that it was not within his domain.

c. Revision of the Developed Materials

On the basis of evaluation, comments, and suggestions given during the expert validation, the draft was revised in the hope that the presentation of the whole materials becomes effective, useful, attractive, clear, appropriate, suitable, and comprehensible to the

students which finally motivate them to learn. After revision, the second draft of the materials was produced.

Figure 1 is presented to summarize the procedure how the draft of the materials was developed.

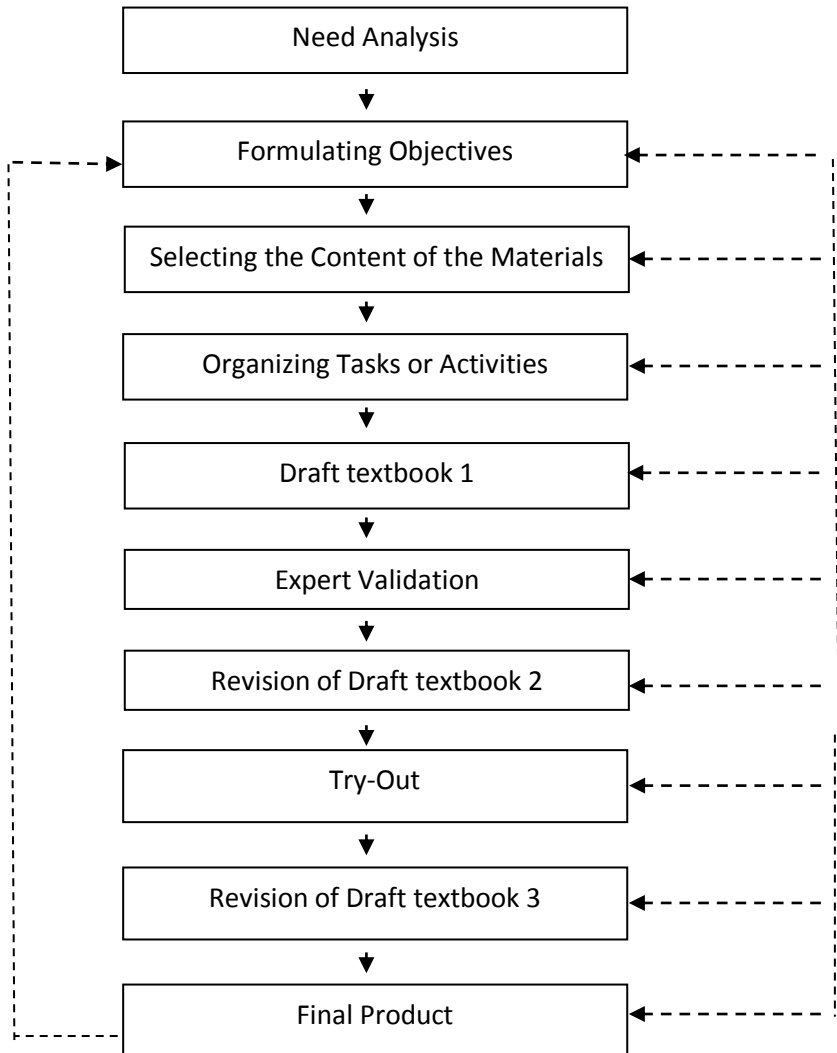

Figure 1 The Procedure of Developing the Draft of the Materials

4. The Try-out of the Developed Materials

After the draft of the materials had been approved by the experts in the validation process, the next thing to do was to try-out the materials. This was a stage in which the draft of the materials was simulated in real teaching and learning setting. Put it in another word, the materials were taught to the students in front of the class through varieties of calssroom interaction and activities.

The revised drafts of the materials were tried-out to find out information about the effectiveness and practicabilities of the materials developed. In addition, the try-out was intended to get feedback whether the developed material were fixed or needed to be revised. The materials would be considered fixed when they were effective in improving the students' achievement in learning English and enhance the students' motivation in learning English, otherwise when they were not effective, it means that the materials should be improved or revised in order to fulfill the criteria or standards of good instructional materials that had been set before.

Because there was limited of time, only two units of the revised draft of the materials were tried-out, namerly units I and II in which each contained six meetings. In line with this, a number of fourth semester students of UIN Mataram were selected to be the subjects of the try-out and they were involved in the try-out process. The choice of the subjects was based on the facts that it was in this semester the students were learning English and English subject was being offered.

During the try-out process in the classroom, the researcher acted as the key instrument; observing the meeting and the learning process, and making a note on any findings which appeared during the process. Here, the researcher observed all the teaching and learning situation for the purpose of collectting information about the implementation of the materials onstudents during the try-out. The researcher also asked for the help of the lecturer whose class was used to try out the materials, to observe the learning and teaching

process when the try-out was going on and to note down about it. This was aimed to help the researcher to elicit information about the teacher and student interaction, student and student interaction, students' activity and participation, and classroom atmosphere during the try out.

For the implementation in the classroom, the try-out of the materials was conducted by giving the students and the colleague lecturer the developed materials to be studied and by distributing questionnaires to the students and to the colleague lecturer at the end of the try-out class to collect data about the applicability of the material in terms of the level of difficulty, usefulness, effectiveness and attractiveness, and to point the area of difficulties or problems that need to be revised. The students and the lecturer were involved in the try-out process to evaluate and give comments and suggestions on the developed materials. In the try-out, the researcher also gave a pre-test to the students at the beginning of the meeting and gave a post-test by the end of the meeting. The pre-test was given to measure the preability of the students before joining the class using the material developed, while the post test was intended to measure the ability of the students after joining the class using the materials developed. Furthermore, these tests were part of the try-out process and they were considered necessary to see the learning achievement and motivation of the students before and after using the developed materials. The followings are the results of the try-out.

5. The Result of Pre-test and Post-test

As stated in the previous section, one part of the try-out activities was to give the students a pre-test at the beginning of the try-out class and a post-test by the end of the try-out class. The tests were intended to see whether there was a change or not in the learning achievement and motivation of the students before and after using the developed materials. In the tests, the students were assigned to do three kinds of tests and the results were presented in the form of table to indicate the learning achievement and motivation of the students. For this purpose,

twenty students in the fourth semester of UIN Mataram were involved as the subjects of the tests. Below was the models of pre-test and post-test given to the students:

MODEL OF PRE-TEST

Direction: Read the text below carefully and do the tasks that follow.

FAMOUS ECONOMIST: ADAM SMITH

Adam Smith (1723-1790), born in Kirkcaldy, Scotland, was educated at Glasgow and Oxford Universities. He became professor of logic and moral philosophy at Glasgow University. His work “An Enquiry into the Nature and causes of Wealth of Nations” (1776) was the first comprehensive study of economics as a separate and independent subject, then known as political economy.

“The wealth of nations” develops a theory of prices and distribution. The price of a commodity, according to Smith, is made up of three elements: wages, rents and profits which are the three original sources of all revenues as well as exchangeable value. Smith also discusses the idea of the embodied labour theory of value. He states that “it was not by gold or by silver, but by labour that all the wealth of the world was originally purchased.” It can be noted that Ricardo and Marx capitalized on Smith’s ideas in developing the labour theory of value.

In his theory of “the determination of prices”, Smith distinguishes between natural and market prices which correspond to the Marshall’s concept of long-run and short-run equilibrium prices. A commodity in the long-run equilibrium price is equal to its natural price which is sufficient to pay wages, rent, and profit.

In the field of production Smith’s most important contribution is his notion of “specialization and division of labour”. He declared that “the division of labour is limited by the extent of the market, by which he means that total production can be expanded through specialization of tasks, provided a market exists to absorb the larger volumes of

production.” Probably Adam Smith’s most original contribution is the concept of the “invisible hand” and the philosophy of “laissez-faire”. The “invisible hand” concept enables Smith argued that the market mechanism has its own regulating system therefore, the state should not intervene through rules and regulation in the price system. He maintains that the motive of every individual in society is self-interest. With the concept of the “invisible hand”, Smith gives every individual the opportunity to promote his own gain. Thus, there is a harmony of individual and social interest. Social interest is simply the sum of the interests of the individuals comprising society.

With the “laissez-faire” philosophy, Smith emphasized freedom of individual enterprise without government interference. The economic system would function best if individuals were free to pursue their own interest. With this concept, Smith tends to support the goal of free international trade. According to him, it does not pay an individual to produce himself. Smith’s “laissez-faire” ideology and free trade philosophy provide support in attempt to reduce barriers to trade.

Given his strong belief in the “laissez-faire”, Smith is skeptical about high public expenditure financed with large amounts of taxes and public debt. He views such an approach to government revenues and spending as the diversion of labour from productive to non-productive activities. Thus, he proposes limiting the state’s function to defense, the administration of justice, and public works, such as roads, bridges and education.

(Source: An Introduction to Modern Economics, By Philip Hardwick, et.al., 1999)\

A. Comprehension Questions

Direction: Answer the following questions based on the text.

1. What information do you get from the first paragraph?
2. What does Adam Smith say about the price of a commodity?
3. What can be inferred from this statement “it was not by gold or by silver, but by labour that all the wealth of the world was originally purchased”?

4. Which of Adam Smith's works discusses a labour theory of value?
5. What are the concepts of "invisible hand" and "laissez-faire"?
6. What does "its" in the fourth paragraph refer to?
7. What does Smith expect with his "invisible hand" and "laissez-faire" concepts?
8. Smith is skeptical about high public expenditure.....(p.6).
What does the word "skeptical" in the sentence mean?

B. Vocabulary

Direction: Find the Indonesian equivalent of each of the words or phrases below.

1. educated
2. comprehensive
3. exchangeable
4. distinguish
5. short-run
6. invisible
7. well-known
8. maintain
9. interest
10. propose

C. Grammar

Direction: Indicate descriptive adjectives in the sentences below which are taken from the text above. You may discuss with your friends.

1. His work "An Enquiry into the Nature and causes of Wealth of Nations" (1776) was the first comprehensive study of economics.
2. Wages, rents and profits are three original sources of all revenues as well as exchangeable value.
3. Smith also discusses the idea of the embodied labour theory of value.
4. A commodity in the long-run equilibrium price is equal to its natural price.

5. He declared that that total production can be expanded through specialization of tasks.
6. Probably Adam Smith's most original contribution is the concept of the "invisible hand" and the philosophy of "laissez-faire".
7. Thus, there is a harmony of individual and social interest.
8. With the "laissez-faire" philosophy, Smith supports the goal of free international trade.
9. Given his strong believe in the "laissez-faire", Smith is skeptical about high public expenditure financed with large amounts of taxes and public debt.
10. He views such an approach to government revenues and spending as the diversion of labour from productive to non-productive activities.

MODEL OF POST-TEST

Direction: Read the text below carefully and do the tasks that follow.

FAMOUS ECONOMIST: ADAM SMITH

Adam Smith (1723-1790), born in Kirkcaldy, Scotland, was educated at Glasgow and Oxford Universities. He became professor of logic and moral philosophy at Glasgow University. His work "An Enquiry into the Nature and causes of Wealth of Nations" (1776) was the first comprehensive study of economics as a separate and independent subject, then known as political economy.

"The wealth of nations" develops a theory of prices and distribution. The price of a commodity, according to Smith, is made up of three elements: wages, rents and profits which are the three original sources of all revenues as well as exchangeable value. Smith also discusses the idea of the embodied labour theory of value. He states that "it was not by gold or by silver, but by labour that all the wealth of the

world was originally purchased.” It can be noted that Ricardo and Marx capitalized on Smith’s ideas in developing the labour theory of value.

In his theory of “the determination of prices”, Smith distinguishes between natural and market prices which correspond to the Marshall’s concept of long-run and short-run equilibrium prices. A commodity in the long-run equilibrium price is equal to its natural price which is sufficient to pay wages, rent, and profit.

In the field of production Smith’s most important contribution is his notion of “specialization and division of labour”. He declared that “the division of labour is limited by the extent of the market, by which he means that total production can be expanded through specialization of tasks, provided a market exists to absorb the larger volumes of production.” Probably Adam Smith’s most original contribution is the concept of the “invisible hand” and the philosophy of “laissez-faire”. The “invisible hand” concept enables Smith argued that the market mechanism has its own regulating system therefore, the state should not intervene through rules and regulation in the price system. He maintains that the motive of every individual in society is self-interest. With the concept of the “invisible hand”, Smith gives every individual the opportunity to promote his own gain. Thus, there is a harmony of individual and social interest. Social interest is simply the sum of the interests of the individuals comprising society.

With the “laissez-faire” philosophy, Smith emphasized freedom of individual enterprise without government interference. The economic system would function best if individuals were free to pursue their own interest. With this concept, Smith tends to support the goal of free international trade. According to him, it does not pay an individual to produce himself. Smith’s “laissez-faire” ideology and free trade philosophy provide support in attempt to reduce barriers to trade.

Given his strong belief in the “laissez-faire”, Smith is skeptical about high public expenditure financed with large amounts of taxes and public debt. He views such an approach to government revenues and spending as the diversion of labour from productive to non-productive activities. Thus, he proposes limiting the state’s function to defense, the

administration of justice, and public works, such as roads, bridges and education.

(Source: An Introduction to Modern Economics, by Philip Hardwick, et.al., 1999)

A. Comprehension Questions

Direction: Answer the following questions based on the text.

1. What information do you get from the first paragraph?
2. What does Adam Smith say about the price of a commodity?
3. What can be inferred from this statement “it was not by gold or by silver, but by labour that all the wealth of the world was originally purchased”?
4. Which of Adam Smith’s works discusses a labour theory of value?
5. What are the concepts of “invisible hand” and “laissez-faire”?
6. What does “its” in the fourth paragraph refer to?
7. What does Smith expect with his “invisible hand” and “laissez-faire” concepts?
8. Smith is skeptical about high public expenditure.....(p.6). What does the word “skeptical” in the sentence mean?

B. Vocabulary

Direction: Find the Indonesian equivalent of each of the words or phrases below.

1. educated
2. comprehensive
3. exchangeable
4. distinguish
5. short-run
6. invisible
7. well-known
8. maintain
9. interest
10. propose

C. Grammar

Direction: Indicate descriptive adjectives in the sentences below which are taken from the text above. You may discuss with your friends.

1. His work “An Enquiry into the Nature and causes of Wealth of Nations” (1776) was the first comprehensive study of economics.
2. Wages, rents and profits are three original sources of all revenues as well as exchangeable value.
3. Smith also discusses the idea of the embodied labour theory of value.
4. A commodity in the long-run equilibrium price is equal to its natural price.
5. He declared that that total production can be expanded through specialization of tasks.
6. Probably Adam Smith’s most original contribution is the concept of the “invisible hand” and the philosophy of “laissez-faire”.
7. Thus, there is a harmony of individual and social interest.
8. With the “laissez-faire” philosophy, Smith supports the goal of free international trade.
9. Given his strong believe in the “laissez-faire”, Smith is skeptical about high public expenditure financed with large amounts of taxes and public debt.
10. He views such an approach to government revenues and spending as the diversion of labour from productive to non-productive activities.

Table 2. The Result of Pre-test

Subjects	Scores	Subjects	Scores
1	63	11	57
2	55	12	43

3	71	13	73
4	53	14	55
5	61	15	64
6	57	16	47
7	36	17	33
8	45	18	61
9	51	19	44
10	67	20	58

The result of the test was unsatisfactory since the distribution of scores showed that the number of subjects who obtained the score with the criteria fail (10%), low (20%), and fair (35%) is greater than those who obtained the score with the criteria good (25%) and very good (10%). It can also be said that the learning achievement and motivation of the students were not good since many of them could not do well on the test given. It seemed that the students needed more and more exercises to improve their reading skill. Table 3 shows the distribution of scores obtained by the subjects in the pre-test.

Table 3. The Distribution of Pre-test Scores

Range	Criteria	Frequency	Number (%)
0-39	Fail	2	10 %
40-49	Low	4	20 %

50-59	Fair	7	35 %
60-69	Good	5	25 %
70-79	Very good	2	10 %
Total		20	100%

The try-out process ended with giving a post test to the students. The post-test was conducted at the last meeting after the try-out class had been finished. Here, the post-test given to the subjects was also in the form of production test containing the same items as the pre-test: comprehension, vocabulary and grammar tests, but they were taken from different section of the units on the draft materials. The result of the test was also displayed in the form of score, made by calculating the correct and wrong answers produced by the subjects. Table 3 presents the result of post-test obtained by each subjects.

Table 3. The Result of Post-test

Subjects	Scores	Subjects	Scores
1	67	11	65
2	60	12	55
3	77	13	78
4	64	14	68
5	68	15	67
6	62	16	60
7	43	17	37

8	56	18	64
9	63	19	56
10	75	20	66

On this test, the students produced a satisfactory result in comparison to the pre-test result. This is shown by the distribution of scores obtained in which many subjects made a significant change of scores so that the number of subjects who obtained the scores with the criteria good (60%) and very good (15%) is greater than those who obtained the scores with the criteria fail (5%), low (5%), and fair (15%). The result of the post-test above indicates that the learning motivation of the students was good enough since many of them could do well on the test given. In another word, there was a change in the students' learning motivation after they had used the developed materials. This also means that when the result of the post-test is better than the result of pre-test, the materials is better developed. Table 4.4 shows the distribution of scores obtained by the subjects in the post test.

Table 4.4 The Distribution of Post Test Scores

Range	Criteria	Frequency	Number (%)
0-39	Fail	1	5 %
40-49	Low	1	5 %
50-59	Fair	3	15 %
60-69	Good	12	60 %
70-79	Very good	3	15 %
Total		20	100%

6. The Result of Observation

One of the important parts of the try-out process was doing observation. It was generally conducted to see the whole process of teaching and learning activities in the classroom. Observation was done during the try-out process of the materials. Here, the researcher collaborated with the colleague lecturer to observe the learning and teaching process in the classroom. The things to be considered as the focus of observation were the students' interest in the topics presented, accomplishment of the tasks given and their usefulness, students' activeness in the teaching and learning process, students' response to the assignments given, presentation of the materials, and the teaching and learning situation during the class. The try-out was conducted in twelve meetings to see the effectiveness and practicabilities of the developed materials, and the achievement and motivation of the students during the learning-teaching process using the developed materials.

The result of observation from the first until the last meeting indicated that the students seemed to be enthusiastic about joining every session of the try-out class. They look curious and eager to know soon the materials to be learned. They seemed to be quite interested in the topics presented on the materials because they knew that the topics they would learn were related to their major content subjects, yet many of them seemed not to be familiar with the kinds of tasks they had to do during the learning and teaching process. They were very serious listening to the explanation of the lecturer and some of them asked questions for clarity.

In the first class of the try-out, the researcher and the colleague lecturer had the impression that the students seemed to be enthusiastic when they were invited to discuss the topics on the materials although some of them still felt reluctant to say something. It could be seen from the fact that many students actively took part in answering and making the questions about the topic discussed and some were just silently listening to their friends speaks. The active

students showed great interest in doing the activities that had been designed before while the less active students tended to show unhappy faces. However, when the researcher encouraged every student in the class to be active, telling them not to hesitate to say something, telling them that they did not need to be afraid of making mistakes, telling them that they could actually do the activities and appraising them for the activities they had done, they then became happier and more active to do the tasks in the next meetings.

The situation of the try-out class became rather smooth after the students were given such encouragements and they really showed eagerness to do the tasks or activities assigned to them. They seemed enjoy answering the questions given, making the questions, giving opinion, reading the texts, speaking in front of the class, discussing the topics with their friends and doing the rest of the tasks. In addition, they looked seriously in listening to what their classmates said or what the teachers explained and modeled in order to catch the information delivered to them. They also seemed to be appreciative to every task their friends did and sometimes they laughed at it. When the teacher delivered information in the written form or on the whiteboard, though it was a very simple one, the students tried to understand it, discussed it with their friends and they once in a while opened their dictionary if they did not understand at all. Besides, they looked so enthusiastic, serious, and active in doing the speaking or the writing tasks given to them as presentation or discussion in front of the class that the class became more alive in spite of the difficulties they found in doing them. The enthusiasm of the students could also be seen when the teacher displayed each work the students had done or give comments to the tasks the students had accomplished. This learning and teaching situation was almost found along the try-out class and it was expected that the materials can really increase the learning motivation of the students.

From those observed phenomena described above, it could be stated that the materials had been able to activate the student's

reading, writing, listening, speaking knowledge and others such as vocabulary and grammar knowledge. The smooth practice of learning and teaching on this knowledge could not be apart from the ability of the materials to activate the student's knowledge of the topics. The materials provided the students with specific topics they were familiar with and which they usually learned in their major content subject. In addition, the materials contained integrated tasks which enabled the students to do various activities in their learning and therefore they became more active. The smoothness of the learning and teaching practice using the materials could not also be separated from the ability of the materials to activate the student's knowledge of the language. The materials were considered to fulfill the needs of the students and suite the level of the students. Based on such good points, it seemed that the materials were quite effective and applicable for the students of UIN Mataram.

7. The Result of the Try-out

The try-out of the developed materials was held by involving the students and the colleague lecturer at UIN Mataram to fill the questionnaires that had been prepared before. With respect to this, twenty students from the fourth semester and one English lecturer were engaged in the try-out class. At the end of the try-out, they were given questionnaires to evaluate as well as to give comments and suggestions on the developed materials and the data obtained from the result of questionnaire were used to make revision. The things to be evaluated were physical appearances of the materials, organization of materials, instructional objectives, topics, list of vocabulary, texts, comprehension questions, grammar review, examples, tasks, directions, coverage of the materials, content of the material, and language. The colleague lecturer and students were also given a special space to give comment and suggestion for better improvement of the draft of the materials.

The result of questionnaires distributed to the students and to the lecturer are the following.

Dealing with the cover design, letters, typing, spacing, and layout of the materials, the students and the lecturer had the same opinion that they were attractive, clear, neat, consistent, and appropriate. Yet, the original materials, the typing, and the chart in unit 4, section 3 need to be improved.

In terms of the organization of the materials both the students and the colleague lecturer said it was attractive and it was appropriately organized in the form of units and sections. The lecturer also said that the organization of the materials was logical in terms of tasks order. About the instructional objectives on the materials, the students and the colleague lecturer stated that they were clear, they could be understood and they were suitable to the needs of the students. The lecturer also stated that they were appropriately stated and ordered.

Regarding the topics, list of vocabulary, and the texts presented on the draft, the students found that the topics were interesting, various and up-to-date, since they were appropriate to their needs and interest and relevant to their content subject. This opinion was also supported by the lecturer who found the same things on the topics presented. Furthermore, the students stated that the lists of vocabulary were presented in appropriate form and they were defined clearly. The lecturer added that the list of vocabulary was well-selected and appropriate for the target situation since they suited the level of the students. Concerning the texts, the students thought that the texts could fulfill their reading taste, they could develop their reading skill and they can help understand their content subject. The lecturer had the same opinion as the students. He also found that the texts were able to raise the motivation and interest of the students since the texts were about economic matters, the major content subject of the students.

In relation to the comprehension questions, the grammar reviews, examples and the tasks, both the students and the lecturer stated that the comprehension questions were comprehensible,

appropriate, and they provided support to the comprehension of the texts. Besides, the lecturer thought that the comprehension questions were helpful to develop the reading skills of the students. But, some questions need to be modified. Dealing with the grammar reviews presented, the students and the lecturer had the same opinion. They thought that the grammar reviews were relevant to their needs, clear, and could be understood. Furthermore, the lecturer stated that the grammar reviews were appropriate to the given context, and they were representative of the underlying grammar rules. About the examples, the students considered that the examples given were clear, appropriate, and could be understood. The lecturer said the same thing as the student. He also added that the examples could define the concepts explained clearly and adequately. Regarding with the tasks, the students considered that the tasks were clear, they could be done, and they could encourage them to be active in the classroom. The opinion was also supported by the teacher in which he said that the tasks could give such an encouragement to the students because they were related to the student's need in their field of study, and they were still in the scope of the student's ability to do them. Besides, according to both the students and the teachers, the tasks could integrate knowledge about the topics and the language learnt.

Concerning the directions, the coverage of the materials, and the content of the materials, the students and the lecturer had the same opinion that the directions were clear, appropriate, and comprehensible. The clarity of the instruction that precede each task helped the students follow and do the tasks on the material. The coverage of the materials according to the students was relevant and suitable to their needs and interest. In addition, the lecturer considered that the coverage of the materials had represented the aspects which could help the students develop their reading skill. About the content of the materials, both the students and the lecturer considered that the content of the materials was clear, relevant, and suitable. So far, the colleague lecturer said that it was logically

ordered, it directly related to the objectives of the instruction and it could be understood by the students.

For the language used on the materials, the students and the lecturer had the same opinion that the language was clear, suitable to the level of the students, and it could be understood by the students. In addition, the lecturer stated that the language could become a model of the correct and meaningful grammatical structures.

Finally, it can be said that the materials were quite applicable in terms of the level of difficulty, usefulness, effectiveness and attractiveness for the students of UIN Mataram. It can also be stated that the material meets the needs of the students in the sense that the materials can develop the reading skill of the students and they can enrich the student's knowledge in their major content subject. This can be seen from the answer of the students and the lecturer in the questionnaires and the result of pre-test and post-test.

8. The Revision of the Tried-out Materials

This was the next stage that should be done after the try-out had been implemented. A revision was still considered necessary because there were some mistakes or drawbacks found on the materials. The revision of the tried-out materials was based on the data collected during the try-out process. By doing a revision, it was expected that the materials would become more appropriate, suitable, comprehensible to the students, and they could fulfill the needs of the students of UIN Mataram. It was also expected that the materials could encourage the students in their attempt to master English and the implementation of the materials would not cause any troubles for the students as well as for the teachers. Based on the data collected during the try-out process, the developed material still had some bad points or weaknesses that need to be revised. The first revision was to improve the physical appearances of the materials. The original materials were not very clear because some words were blurred and

unreadable. The second revision was to complete the typing of the materials. There were some missing words in the typing of the original materials. The third was to revise the comprehension questions. Some questions were not clear and rather difficult to understand by the students; therefore, they need to be modified. The last was to add the chart in Unit 5, Section 3 with lines. They were not complete yet.

9. The Final Product

After the materials had been revised, the development of the materials in this study resulted in the final product which was in the form of reading comprehension materials for the students of Economics Department at UIN Mataram. The materials were developed on the basis of the data collected from the analysis of the needs of the students and revision was made based on the data collected from the experts during the validation process, the students and the colleague lecturer during the try-out process which was expected to help the students to learn English. Finally, the materials were still possible to be revised, if some weaknesses or deficiencies are found in its real implementation.

B. Discussion

This study is aimed at developing suitable reading comprehension materials for the students of UIN Mataram. This language skill becomes important to be taught to EFL students since it can be used as the tools for the teaching of other language skills. In this case, reading materials play a pivotal role in attempt to facilitate the students in learning reading better. With the availability of reading materials in the classroom, teachers can bring the students to the real application of reading.

Reading is the process of getting the meaning of printed or written information stated by the author. Here, there is a combination of language skills and knowledge of the real world to catch the meaning of the texts being read. Meanwhile, reading comprehension is the ability to understand texts and its meaning and to integrate with the previous knowledge of the reader. Some basic skills needed for effective and efficient reading comprehension are understanding the meaning of words, the ability to understand the meaning of a word according to context, the ability to identify organization of the text, to identify antecedents and references in the text, the ability to make inferences from the text, the ability to identify the main idea of the text, the ability to answer questions based on the text, ability to recognize the ability to determine writer's purpose, intent and point of view, and draw inferences.

Reading comprehension instructional materials developed in this study was based on the students' needs. As we know that students have different need in their learning and they will learn better as the teachers can provide the students with the materials that match with students' needs. The reading materials developed in this study has a number of important characteristics. *First*, it was developed in the form of course book containing reading comprehension materials, which is designed according to the needs and characteristics of the students and the goal stated in the curriculum of UIN Mataram. In general, this course book contains a set of materials that will be implemented in the teaching and learning activities of reading comprehension course. Specifically, it contains reading texts of intermediate level (approximately 3000 words) and tasks designed for the fourth semester students of UIN Mataram. *Second*, the course book was designed in the form of units, in accordance with the objectives of the course as stated in each section of the book, in this case, several units have been developed within the course book which specifically deal with the major of the students. Here, the course book is divided into three units containing

two up to four sections in which each section contains texts which involve items such as: comprehension questions, writing tasks, speaking tasks, listening tasks, vocabulary tasks, grammar reviews, and grammar tasks. By presenting specific topics to be learned and dividing the topics into units and sections, the material is expected to represent the needs of the students and fulfill what they actually need to learn. On the other hand, with the exploitation of the texts into integrated skill tasks in each unit, the students would do various activities to improve their knowledge in the four skills of English. Furthermore, the presentation of grammar reviews and grammar tasks in each unit will give a chance to the students to learn the model of language use. *Third*, some activities have been designed to conduct the instruction in the classroom; in this case, lecturing, presentation, homework, and class discussions are chosen to be the activities. *fourth*, materials in the course book are adapted from a number of sources (books, newspapers) especially those that are relevant to the content subject of the students. It is hoped that the materials can be a guide for the teachers and that they can encourage the students to learn.

The course book as the product developed in this study has also some strengths and limitations. The strengths of this course book are the followings. *First*, this course book is designed according to the needs of the students and the demand of the curriculum. *Second*, it can be used to help students improve their reading comprehension skills and higher order thinking skills. *Third*, it can help the students develop their knowledge in the content subject they are majoring. *sixth*, it gives emphasis on the comprehension of the whole texts, but at the same time, it gives chance to the study of vocabulary and grammar and content knowledge. *fourth*, the coursebook tries to integrate oral and written English tasks in learning activities by discussing and writing what is being read. Through these activities, the students can improve their English in the four language skills. *fifth*, In this course book, the teacher gives

more chances to the students to do some comprehension tasks by questioning, predicting, discussing, analyzing the text, etc. Besides, the teacher gives opportunity to the students to state their opinion, to response others, to hear from others, to discuss their ideas, etc.

This course book also has a number of limitations. *First*, the result of need analysis as the basis for developing materials in this course book cannot accommodate all students, so that it cannot represent all students' needs. *Second*, this course book is only suitable for the students from particular discipline because the content is mostly related to particular subject. This course only has a qualitative effectiveness and practicabilities, therefore, it needs to be examined to know its further effectiveness; by doing experimental research.

CHAPTER X CONCLUSION AND SUGGESTION

A. Conclusion

From the discussion about the result of material development in the previous chapter, the following conclusion can be drawn:

1. The students UIN Mataram need reading materials which connect to their field of study namely economics. This was reflected in the result of the needs analysis in which most of the students and the lecturers agree to develop reading materials which are suitable to their major content subject, to include list of vocabulary in the reading materials they are learning, to include grammar review in the future reading materials, to clarify the content of the materials in the explanation, and to arrange the materials according to the degree of its difficulty.
2. The result of development in this study are reading comprehension materials in the form of textbook containing topics, texts, comprehension questions, integrated skill tasks, vocabulary tasks, grammar reviews, and grammar tasks which are developed based on the needs and interest of the students of UIN Mataram.
3. The materials developed have a number of good and weak points after the experts (i.e. reading and content expert) give evaluation; therefore, the weak points of the materials need to be improved and revised.
4. The materials developed are quite applicable for the students in terms of effectiveness, usefulness, attractiveness, appropriateness, the clarity of content, and the level of difficulty in the try out class although some aspects of the materials need to be revised and improved.
5. The students are quite motivated to learn the materials developed. Most of them show high enthusiasm in joining every session of the try-out class and their learning mastery change significantly

after using the materials which is reflected in their pre-test and post test results.

B. Suggestions

Regarding with the implementation of the developed materials in the teaching and learning process and the weaknesses of development in this study, there are some suggestions to be proposed namely:

1. It is suggested for other English lecturers at UIN Mataram to prepare course materials which are appropriate to the students i.e. relevant to the major content subjects of the students.
2. It is suggested for the lecturers who teach English at UIN Mataram to immediately use the developed materials as course materials after the materials has been socialized.
3. The lecturer is suggested to revise the materials if he or she finds some drawbacks in the implementation of the materials for better improvement.
4. It is suggested that the lecturer should have creativity in implementing the materials, so that the students become motivated to learn, to be more active in their learning, and they do not feel bored.
5. The students of UIN Mataram are suggested to use the materials for the improvement of their reading ability in English.
6. The institution is suggested to use the product developed as a model of reading materials that can be used to teach the students of UIN Mataram.
7. Because the development in this study is not supported with the data which confirm the student's disagreement on the items in the needs analysis, it is suggested for the future researcher who will conduct similar research to consider this weakness deliberately for better result of development.

8. The development in this study also does not involve the content lecturer in exploring the needs of the students; hence, it is suggested to do this in the next research.

C. Implication

In developing instructional material, students' needs should be taken into consideration. Different students have different needs. The students will be more interested and motivated to learn (including learning English) when the materials given are in accordance with their needs. Thus, English reading comprehension materials as one of the tools to develop the reading skill of the students should be relevant to the content major subject of the students. It is expected that by providing the students the so called materials, achievement and motivation of the students in learning English reading can be increased.

REFERENCES

- Alexander, J.E. *Teaching Reading*. Boston: Scot, Foresman and Company, 1998.
- Ary, Jacobs, Razavieh. *Introduction to Research in Education*. Canada: CBS Colledge Publishing, 1985.
- Alexander, J.E. *Teaching Reading*. Boston: Scot, Foresman and Company, 1998.
- A Athanasou, James and Lamprianou, Iasonas, *A Teacher's Guide to Assessment*, Social Science Press, 2002.
- Arias, Ivannia Jiménez. "Selecting Reading Materials Wisely." *Letras*, no. 41 (2007), 131–151.
- Allehyani, et al. "A Comparison of Teaching Materials (School Textbooks Vs Authentic Materials) from the Perspective of English Teachers and Educational Supervisors in Saudi Arabia." *International Journal of English Language and Linguistics Research* 5 no. 2 (2017), 1-14.
- Abdu-Raheem, B. O. "Availability, Adequacy and Utilisation of Social Studies Instructional Materials in Ekiti State Secondary Schools." *Journal of Current Discourse and Research* 3, no. 1 (2017), 242-255.
- Ajoke, Alabere Rabiati. "The Importance of Instructional Materials in Teaching English as a Second Language Education and Modern Languages, Universiti Utara Malaysia/CAILS, Ilorin, Nigeria." *International Journal of Humanities and Social Science Invention* 6, no. 9 (2017), 36-44.
- Apsari, Yanuarti and Haryudin, Acep "The Analysis of English Lecturers'Classroom-Based Reading Assessments to Improve Students'Reading Comprehension." *ELTIN*

JOURNAL, Journal of English Language Teaching in Indonesia
5, no. 1 (2017), 35–44.

Ates, Huseyin and Buyukkarci, Kagan. “Teachers’ Perceptions of Assessment in EFL Classes at Turkish Science and Art Center.” *International Journal of Languages’ Education and Teaching* 7 no. 2, (2019), 294-318.

Adil, Muhammad. Importance of English Language for the Students in Education. Accessed on August 2021. <https://adilblogger.com/importance-english-language-students-education/>

Borg, W. and Gall, M.D. *Educational Research: An Introduction*. New York: Longman, Inc., 1996.

Burn, Paul C, et al. *Teaching Reading in Today’s Elementary School*. London: Hough ton Mifflin Company, 1999.

Brown, D.H. *Teaching by Principle: An Interactive Approach to Language Pedagogy (2nd Ed.)*. New York: Addison Wesley Longman, Inc., 2001

_____. Douglas. *Language Assessment Principles and Classroom Practices*. New york: Pearson Education, Inc., 2004.

Buku Pedoman Penyelenggaraan Pendidikan UIN Mataram. 2005.

Brown, Abbie H and Timothy D Green, *The Essentials of Instructional Design: Connecting Fundamental Principles with Process and Practice*, Routledge, 2019.

Basturkmen, Helen “ESP Teacher Education Needs,” *Language Teaching* 52, no. 3 (2019): 318–330.

_____, Helen, *Developing Courses in English for Specific Purposes*, Springer, 2010.

- Coffman, William E, "On the Reliability of Ratings of Essay Examinations in English," *Research in the Teaching of English* 5, no. 1 (1971): 24–36.
- Cunningsworth, Alan. *Choosing Your Coursebook*. Macmillan, 1995.
- Cooper, J.D. *Literacy: Helping Children Learn to Read*. Boston: Houghton Mifflin Company, 2000.
- Crystal, David. *English as a global Language* (2nd Ed.). Cambridge: Cambridge University Press, 2003.
- Carneson, John, Georges Delpierre and Ken Masters, *Designing and Managing Multiple Choice Questions*, Retrieved March 30 (1996): 2008.
- Dick, W and Carey, L. *The Systematic Design of Instruction*. USA: Harper Collins Publishers, 2001.
- Day, R.R. 1994. Selecting a Passage for The EFL Reading Class. *English Teaching Forum* 32, no. 1, (1994): 20-24.
- Dunn, Lee Chris Morgan, and Sharon Parry, *Seeking Quality in Criterion Referenced Assessment*, 2002.
- Drubin, D. G. and Kellogg, D.R. *English as Universal Language of Science: Opportunities and Challenges*. America: Mol.Biol. Cel, 2012.
- D'Angelo, Tyler, J C Bunch, and Andrew Thoron, "Instructional Design Using the Dick \& Carey Systems Approach," *EDIS* 2018, no. 2 (2018).
- Essef, P.J. *Developing Instructional Material*. Columbia: ESF Press, 1980.
- Ellington, H. *Producing Teaching Materials: A Handbook for Teachers and Trainers*. London: Kogan Page Ltd., 1985.

- Erlina, Dian., Ilza Mayuni, Sabarti Akhadiah. Whole Language-Based English Reading Materials *International Journal of Applied Linguistics & English Literature* 3, no. 3 (2016), 46-56.
- Gillet, Jean Wallace and Temple, Charles A., *Instructor's Manual to Accompany Understanding Reading Problems: Assessment and Instruction*. Little Brown, 1986.
- Gustafson, Kent L. *Survey of Instructional Development Models* (ERIC Clearinghouse on Information & Technology, 1991).
- Goodman, K. The Reading Process. in Carel, P.L. Devine, J and Eshley, D.E. *Interactive Approaches to Second Language Reading*: New York, The Process Syndicate of the University of Cambridge, 1998.
- Gebhard, J.G. *Teaching English as Foreign or Second Language*. Michigan: The University of Michigan Press, 2000.
- Gedung D Lt and Mandikdasmen Jl R S Fatmawati, *Badan Standar Nasional Pendidikan*, 2006.
- Grabe, William and Jiang, Xiangying. "Assessing Reading." *The Companion to Language Assessment* 1 (2013), 185–200.
- Gilakjani, Abbas Pourhosein and Sabouri, Narjes Banou. "How Can Students Improve Their Reading Comprehension Skill." *Journal of Studies in Education* 6, no. 2 (2016), 229–240.
- Grumilah, Apsus and Aji, Irfan Nur. "Informal Assessment for Language Skills: The Learners' Perspective." *International Conference on Education and Language (ICEL)*, 2016, 81.
- Hamayan, E. *Current Trend in ESL Curriculum. Second Language Curriculum. Resource Handbook. A practical Guide for K-12 ESL Programs*. New York: Kraus International Publications, 1993.

- Hornby, AS. 1995. *Oxford Advanced Learner's Dictionary*. (5th ed.). oxford university press
- Halim, T. 1999. *Developing Reading Comprehension Materials for Graduate Students of the State University of Malang*. Unpublished Thesis. Malang: PPS UM.
- Hardwick, P., Khan, B and Langmead, J. 1999. *An Introduction to modern Economics* (5th ed.). England: Pearson Education Limited.
- Hutchinson, T and Waters, A. *English for Specific Purposes: A Learning-Centered Approach*. Cambridge: Cambridge University Press, 1991.
- Hutchinson, T. and Torres, E. "The textbook as agent of change." *ELT Journal* 48, no.4 (1994), 315-28.
- Harmer, Jeremy. *How to Teach English: An Introduction to the Practice of English Language Teaching*. England: Addison Wesley Longman Limited., 2011.
- _____. *The Practice of language Teaching*. London: Cambridge University Press, 2001
- _____. *How to Teach English*. Harlow: Pearson Education Limited, 2007.
- Hedge, T. *Writing* (2nd ed.) Oxford: Oxford University Press, 2005.
- Habib, M. "Assessment of Reading Comprehension." *Revista Romaneasca pentru Educatie* 8, no. 1 (2016), 125-147
- <https://Dictionary.Cambriddge.Org>.
- Jerffries, L. and Mikulecky, S. Beatrice. *More Reading Power*. USA: Longman, 1996.
- James, Richard, McInnis, Craig and Devlin, Marcia, *Assessing Learning in Australian Universities: Ideas, Strategies and Resources for*

Quality in Student Assessment, Australian, Universities Teaching Committee, 2002.

Nitko, J Anthony and Susan Brookhart M., *Education Assessment of Students*, New Jersey: Merrill Prentice Hall, 2007.

Joshua, Chukuwemeka Emeka et al., “A Review of Instructional Models for Effective Teacher Education and Technology Integration,” *Sumerian Journal of Education. Linguistics and Literature* 3, no. 6 (2020), 86–95.

Kempton, J.E. *Instructional Design: A Plan for Unit and Course Development*. California: Fearon-Pitman, 1977.

Kurikulum UIN Mataram 1994

Kaur, Sarjit, “ESP Course Design: Matching Learner Needs to Aims,” *English for Specific Purposes* 6, no. 1 (2007): 25–37.

Kirkgoz, Yasemin., Muzaffer P.B., Reyhan Agcam.” Turkish EFL Teachers’ Perceptions and Practices of Foreign Language Assessment in Primary Education.” *Journal of Education and e-Learning Research* 4, no.3 (2017), 163-170.

Kukreja, Sonia. “Purpose of Reading. Accessed on May 2021 <https://www.managementstudyhq.com/purpose-and-process-of-reading.html>

Luminet, Olivier et al., “Relation between Alexithymia and the Five-Factor Model of Personality: A Facet-Level Analysis,” *Journal of personality assessment* 73, no. 3 (1999): 345–358.

Love, Terence and Trudi Cooper, “Designing Online Information Systems for Portfolio-Based Assessment: Design Criteria and Heuristics,” *Journal of Information Technology Education: Research* 3, no. 1 (2004): 65–81.

- McNeil, J. D. *Reading comprehension: New Dimension for Classroom Practice*. Los Angeles: Harper Collins Publishers, 1992
- Lightbown, P.M., & Spada, N. *How Languages Are Learned (4th ed.)* Oxford: Oxford University Press, 2013.
- McNeil, J.D. *Reading Comprehension*. Scott: Foresman and Company, 1984.
- Morray, M.K. 1991. INELEC. Team work in EST Program: *English Teaching Forum*, Vol. XIX No. 1, January 1991 pp 18-21.
- Morales, C.L.C., A.M. Quiroga Rodríguez & L.Y. Oliveros Urrego and P.A Rodríguez González., “English Curriculum Proposal Based on a Needs Analysis Study of Efl Learners in Elementary Grades at Escuela Normal Superior Distrital María Montessorri,” *ENGLISH EDUCATION JOURNAL (EEJ)*, 9, no. 4 (2010): 589–613.
- Miarso, Y. H. “Survei Model Pengembangan Instruksionale makalah Yang Disampaikan Sebagai Bahan Ajar Kuliah Mahasiswa S3 Program Studi Teknologi Pendidikan Pascasarjana UNJ” (2011).
- Nunan, David. Principle for Designing Language Teaching Materials: *Guidelines Periodical for Classroom Language Teachers Vol. 10 No. 2*. Singapore: SEAMEO Regional Language Center, 1988.
- _____. *Second Language Teaching & Learning*. USA: International Thomson Publishing Company, 1999.
- _____. *Language Teaching Methodology: A textbook for teachers*. New York: Prentice Hall, 1991.
- Nutall, C. *Teaching Reading Skills in a Foreign Language*. London: Heineman Educational Book Ltd., 1989

- Nwachukwu C. E. *Designing Appropriate Methodology in Vocational and Technical Education for Nigeria*. Nsukka University: Trust Publishers, 2006.
- Nitko, J. Anthony and Susan Brookhart M. *Education Assessment of Students*. New Jearsey: Merrill Prentice Hall, 2007.
- O’Neill, Robert. “Why Use Textbooks?.” *ELT Journal* 36, no. 2 (1982), 104–111.
- O’Dell, F. *English as a Foreign Language Preliminary Examination*. London and New York: Longman, 1987.
- Orr, T. (Ed.). *English for Specific Purposes*. Virginia: Teacher of English to Speakers of Other Languages, Inc., 2002.
- Omabe, C. C. *Instructional Materials for Social Studies Education in Nigeria*. Abakaliki: Willy Rose and Apple seed publishers, 2006.
- Patel, M. F. & Jain, Praveen M. *English Language Teaching*. Jaipur: Sunrise Publisher & Distributors, 2008
- Robinson, K.G. *Curriculum Evaluation for Life Long Education*. Oxford: Pergamon Press, 1978.
- Rumelhard, D. *Toward an Interactive Model of Reading*. New York: Academic Press, 1880.
- Richard, J.C. *Teaching English for Science and Technology*. Singapore: Singapore University Press, Ltd., 1985.
- Richard, J and T. Rodgers. *Approaches and Methods in Language Teaching*. Cambridge: Cambridge University Press, 1986.
- Robins, S.P, *Organizational Behavior: Concepts, Controversies, Applications*, New York: Prentice Hall, Inc., 1996.
- Richards, J.C. *Curriculum Development in Language Teaching*. Cambridge: Cambridge University Press, 2001.

- Stevens, Peter, *ESP After Twenty Years: A Reappraisal, ESP: State of the Art*, 1988.
- Rochmawati, *English Curriculum and Material Development*, 2017.
- Rashtchi, Mojgan and Reza Porkar, “ESP Courses and Identity Formation: The Case of Introvert Students,” *International Linguistics Research* 3, no. 1 (2020), 29-29.
- Searfoss, L.M. and Readance, J.E. *Helping Children learn to read*. Boston: Allyn and Bacon, 1994.
- Seel, B. and Riche, R.C. *Instructional Technology: The Definition and Domains*. Washington D.C: Association for Educational Communication and Technology, 1994.
- Susila, D. 1994. *Pengembangan Materi Pengajaran Bahasa Inggris Untuk Mahasiswa Fakultas Ekonomi Universitas Muhammadiyah Bengkulu*. Unpublished Thesis. Malang: FFS IKIP Malang.
- Snow, C. *Reading for Understanding: Toward a Research and Development Program in Reading Comprehension*. Santa Monica: Rand Education, 2002.
- Soenarto, *Metodologi Penelitian Pengembangan untuk Peningkatan Kualitas Pembelajaran*. Jakarta: PPTK dan KPT, 2005.
- Sunarti, Subana, *Strategi Belajar Mengajar Bahasa Indonesia*, Bandung: Pustaka Setia, 2009.
- Suparman, Atwi, *Desain Instruksional Modern*, Jakarta: Penerbit Erlangga, 2012.
- Spyropoulou, anastasia. Accessed on August 2021. <https://www.linkedin.com/pulse/significance-elt-coursebook-anastasia-spyropoulou>.
- Thonis, W. *Teaching Reading to Non-English Speakers*. New York: The Mackmillan Company, 1970.

- Twelker, Paul A et al. “*The Systematic Development of Instruction: An Overview and Basic Guide to the Literature*. 1972.
- Tierney, et al. *Reading Strategies and Practices: A Compendium*. Boston: Allyn and Bacon, Inc., 1985.
- Tomlinson, B and Masuhara, H. 2004. *Developing Course Materials: RELC Portfolio Series 11*. Singapore: SEAMEO Regional Language Center.
- Tomlinson, Brian, *Principles and Procedures for Self-Access Materials, Reading* (2011).
- Taher, B., & Tam, S. S. Informal Language Learning Setting: Technology or Social Interaction? *The Turkish Online Journal of Educational Technology* 11, no. 2 (2012), 142–149.
- Tim Paradigma Pendidikan BSNP, *Paradigma Pendidikan Nasional Abad XXI*, Jakarta: Badan Standar Nasional Pendidikan, 2010.
- The Importance of English for College Students. Accessed on Agust 2021. <http://britishcourse.com/the-importance-of-english-for-college-students.php>.
- Usadiati, W. 1999. *Developing A Model of ESP Reading Materials for Team-Teaching Using Content Based Approach*. Unpublished Thesis. Malang: PPS UM.
- Vacca, J.A.L., Vacca, R.T., and Grove, M.K. *Reading and Learning to Read*. New York: Harper Collins Publisher, 1991.
- Woodward, Helen, “Reflective Journals and Portfolios: Learning through Assessment,” *Assessment/Evaluation in Higher Education* 23, no. 4 (1998): 415–423.
- Widianti, Utami and Yudi Cahyono, Bambang. The Teaching of EFL Reading in the Indonesian Context: The State of the Art. *Jurnal Bahasa & Sastra*, 17, no 1 (2006), 36-58.

<https://sites.google.com/view/theeltpractitioner/archive/2018/volume-v-number-iii/2-role-of-materials-development-for-english-language-learning-and-teaching>, (Accessed on September, 20)

SYNOPSIS

The book which is entitled “Reading Comprehension Instructional Design (A Dick and Carey Model)” is a helpful and suitable book for those who are interested in the field of instructional design, especially in English Language Teaching context.

This scientific work is compiled in the form of a reference book which presents the result of the study by employing research and development procedures which is often known as R&D. In this book, the model applied in the process of developing and designing a coursebook as the product of this study is the Dick and Carey model. which encompasses a number of steps, starting from identifying instructional goals to conducting summative evaluation.

The major focus of the study in this book is the development of an instructional tool containing reading comprehension materials for the teaching of English at Higher Education. Specifically, the material in this book is aimed at providing the students with the knowledge of comprehending English text and to introduce to them English vocabularies and grammatical structures. Furthermore, this book also presents a number of most relevant and up to date theories as well as practical knowledge which is directly related to the issues discussed in this book.. By reading this book, readers are expected to be able to obtain a concrete model of the steps for developing and designing instructional tools, especially for the teaching and learning of English and to put them in the form of ideas and scientific works. Last, this book is hoped to bring advantages for the teachers and it can become a guide and referent for them in designing and implementing their English courses.

Happy reading.

GLOSARIUM

C

Coursebook:: a textbook that students and teachers use as the basis of a course. It plays a significant role in EFL teaching and learning by providing useful ready-made material to both teachers and students.

E

English for Spesific Purposes (ESP): an approach to language learning aiming at teaching the English language needed for specific situation, mainly related to academic (EAP) orroccupational (EOP) contexts. Therefore, an ESP course is developed based on the analysis of purposes and needs and the activities for which English is needed.

Expert Validation: the process of judging and evaluating the materials developed by experts. This is a preliminary testing by involving some experts to evaluate the materials developed and to get input and approval from the experts.

I

Instructional Development: a systematic process in identifying problems, developing instructional materials and strategies, and evaluating their effectiveness and efficiency in achieving instructional goals. So far, it contains organized procedure that include the steps of analyzing, designing, developing, implementing, and evaluating instruction.

Instructional Design: The process of identifying learning needs and development learning material in order to improve instructions to the learners The instructional design process consists of determining the needs of learners, defining the end goals and objectives of instruction, designing and planning assessment tasks, and designing teaching and learning activities to ensure the quality of instruction.

Interview: instrument used for gathering information or collecting the data needed in a research. This is an appropriate method when there is a need to collect in-depth information on people's opinions, thoughts, experiences, and feelings.

M

Model: a plan or a pattern that can be used to design instruction and to shape instructional materials. It may contain an object, plan, or set of rules that is used to show what something else is like or how it works.

Material Development: all the processes used to produce materials for language learning, including materials evaluation, their adaptation, design, production, exploitation and research of language teaching materials.

N

Needs Analysis: procedures used to collect information about students' needs. It is conducted to obtain information about the type of needs on the basis of the existing learning teaching situation and the needs of the students.

R

Reading Assessment: the process of gathering information to monitor the students' progress in learning reading. The English teachers should motivate students in reading through an appropriate assessment.

Reading comprehension: an interactive process between the writer and reader, with the expression and reception of meaning as the primary goal of both parties.

Reading Materials: everything used to help teaching reading. It can come from literature, songs, newspapers, magazines, non-

fiction books, radio and television programmers and from films, etc.

Q

Questionnaire: a research instrument containing a series of questions for the purpose of gathering information from respondents.

T

The Dick and Carey Model of Instructional Design: a model of instructional design containing a nine step process for planning and designing effective learning activities.

Try-out: the process of giving the students and the colleague lecturer the developed materials to be studied and by asking them to evaluate and give comments and suggestions on the developed material. It has the purpose of collecting data about the applicability of the material in terms of the level of difficulty, usefulness, effectiveness and attractiveness, and to point the area of difficulties or problems that need to be revised.

CURRICULUM VITAE



Ribahan was born on July 23, 1979 in Lombok Timur, West Nusa Tenggara. He finished his elementary school in 1991 and junior high school in 1994. After he graduated from senior high school in 1997, he continued his study to the English Department of the Faculty of Letters of Udayana University, Denpasar and in 2002, he obtained his S1 degree. In 2003, he was appointed as one of the permanent English lecturer at UIN Mataram. Doing his first duty as a lecturer, he was posted at Faculty of Shari'ah and he taught English as a general subject in several study programs in the faculty. Three years later, exactly in 2005, he took his master study at the Postgraduate Program of Malang State University - East Java, majoring in English education and succeeded in completing his study in 2008. Then, in 2018, he gained a doctoral degree from the Postgraduate Program of Ganesha University of Education, Singaraja - Bali, specialized in English education. Currently, he is a permanent lecturer at English Study Program, Faculty of Teacher Training, UIN Mataram. Some of his works are: *English for Economics (Buku Ajar, 2014)*, *Developing English Syllabus for the Students of Family Law, Faculty of Law and Islamic Economics, UIN Mataram (Artikel, 2015)*, *Pengajaran Prosa Menggunakan Pendekatan Kolaboratif Tipe Investigasi Kelompok (Artikel, 2016)*, *Motivation, Attitude, Need, and Evaluation of the Students of UIN Mataram in Learning English as a General Subject to Deal with Globalization Era (Artikel, 2017)*, *Students' Perceptions of the Characteristics of Effective English Teachers at Mataram State Institute of Islamic Studies, Lombok (Artikel, 2018)*, *Integrated - Communicative English (Buku Ajar, 2019)*, *Desain Perangkat Pembelajaran Bahasa Inggris Komunikatif – Integratif: Teori, Teknik, dan Implementasinya (2020)*.